

.....

Large 6 Door

LOCKER

.....

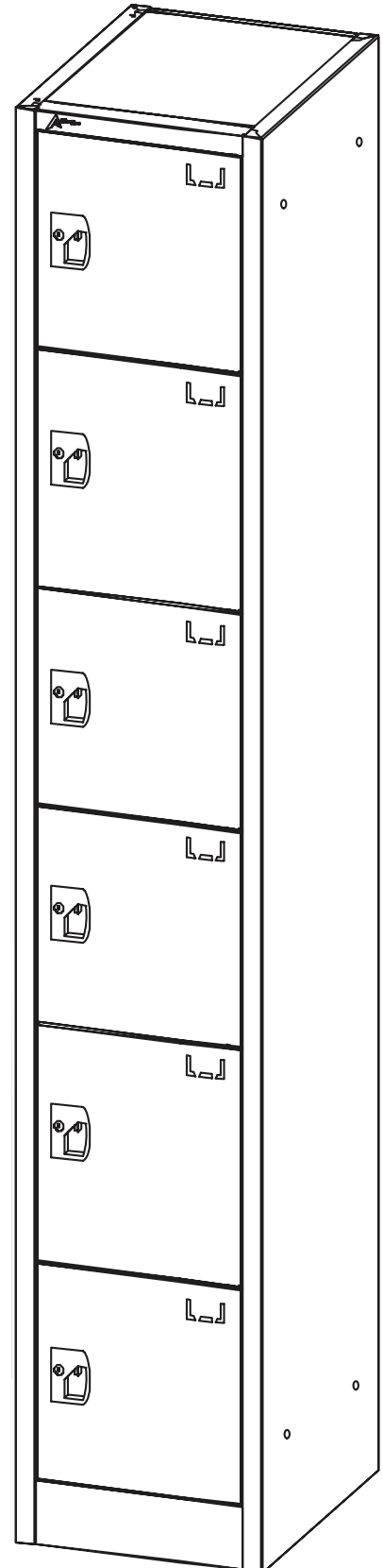

ADI629-206-SERIES
USER GUIDE

	 WARNING: CHOKING HAZARD Be Careful of SHARP EDGES Not for children under 3 years.
---	---



Thank you for your purchase.

.....

AdirOffice maintains a strong practice of ongoing development of products and commercial research.

.....

We understand starting and maintaining a business is expensive enough. We can help make it cost effective and beautiful. Plus, our expert team makes sure everything you need works as efficiently as possible.

Table of Contents

- 1 Introduction
- 2 Parts
- 3 Hardware
- 4 Assembly Instructions
- 10 Installation Instructions
- 12 Warranty

Introduction

The AdirOffice Large 6 Door Locker is designed to provide storage and security for your home or office. The lockers are conveniently designed so that they can be installed with multiple units if desired.

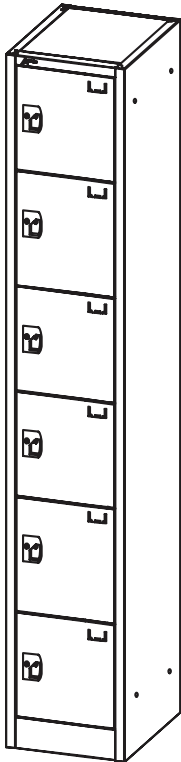

Single unit

Use a single, standalone unit.

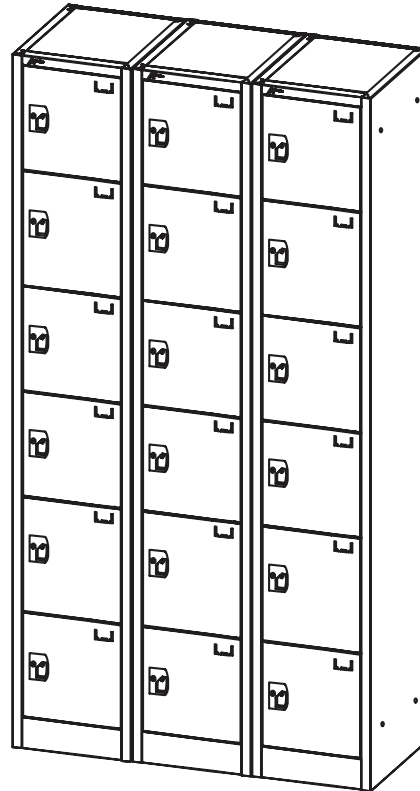

Multiple units

Mount multiple lockers together.

BEFORE YOU BEGIN



- You will need a large space to assemble your locker.
- Take precaution to protect your floor by placing a carpet or pad underneath your work area.
- Panel edges can be sharp, so gloves are recommended.
- Assembly and installation can be completed by one person.
- Mount the locker(s) to a wall for optimal safety.

Parts

- A. Left Panel
- B. Back Panel
- C. Right Panel
- D. Door Panel

- E. Top Panel
- F. Middle Panel
- G. Bottom Panel

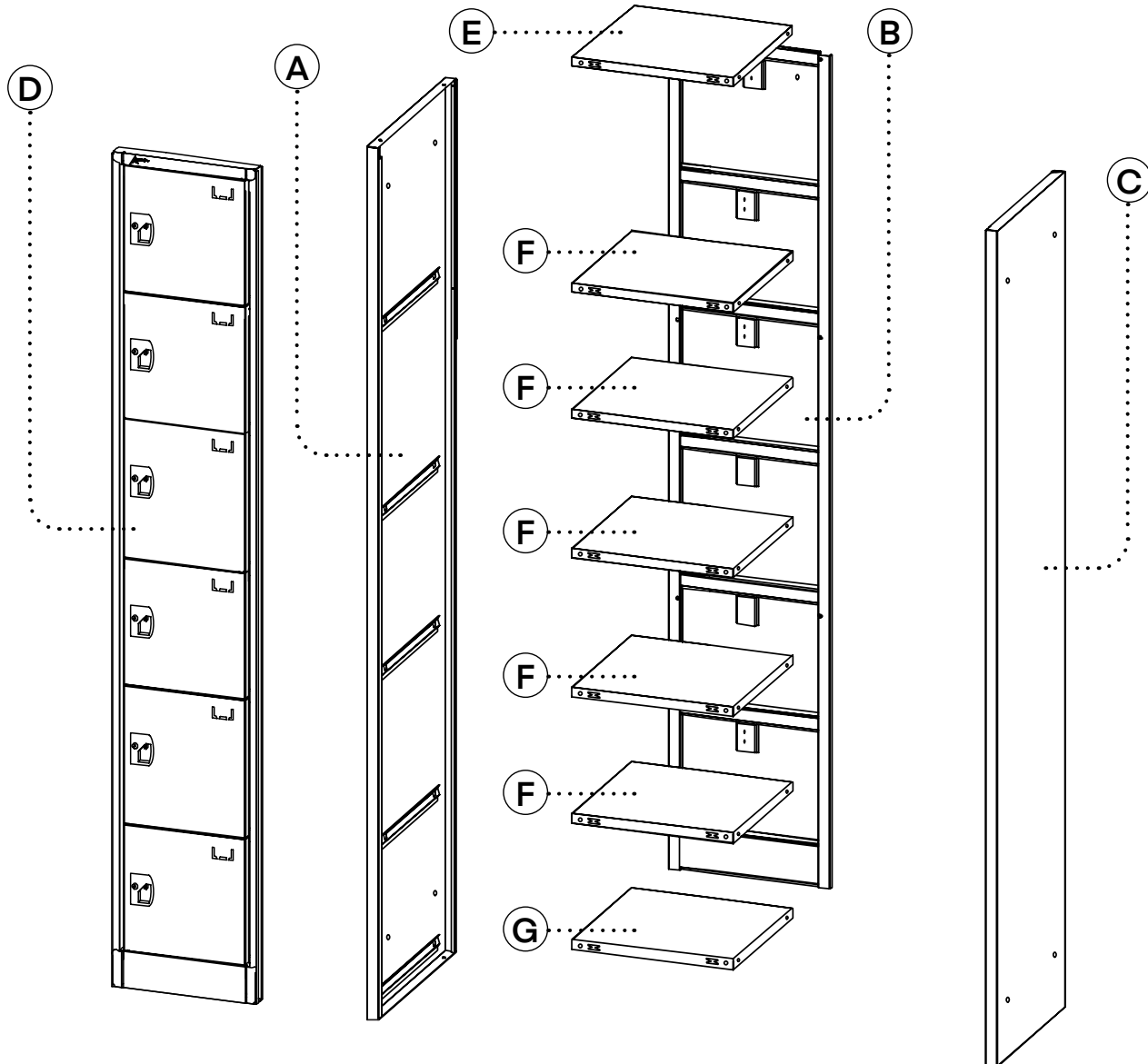





NOTE:

- When installing the Top Panel, you will only need to screw in the **two** corner screw holes. There will be a middle screw hole that doesn't require a screw.
- When installing the Bottom and Middle Panels, you will only need **one** screw in the middle screw hole. There will be two corner screw holes that don't require a screw.
- The top, bottom and middle shelves for this locker are interchangeable.

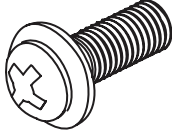
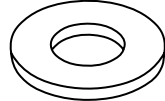
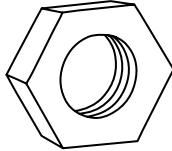
Hardware

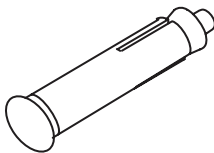
The AdirOffice Large 6 Door Locker is designed to provide storage and security for your home or office. The lockers are conveniently designed so that they can be installed with multiple units if desired.

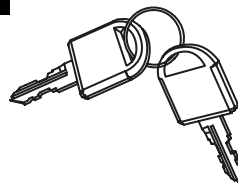
1  Bolts (x4)	2  Washers (x4)	3  Nuts (x4)	4  Round Head Screw (x24)
5  Wall Anchors (x2)	6  Double Hooks (x6)	7  Keys (6 sets of 2)	

Tools Required (But Not Included):

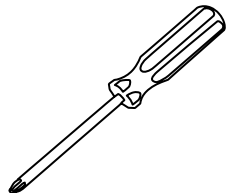
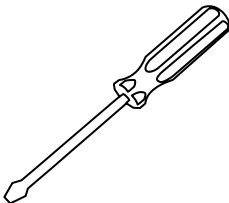
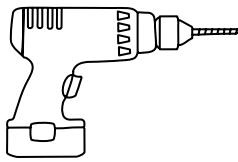
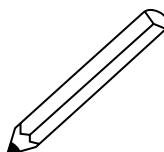
 Philips head screwdriver	 Flat Head Screwdriver	 Drill and Drill Bit	 Pencil
---	--	---	---

Assembly Instructions

Step 1:

- A. Starting on a flat surface, place the Left Panel (A) onto the left side of the Back Panel (B).
 - a. You can build this standing up, but, it is easier and safer to begin this process by building the locker lying down.
- B. Line up the "C" shape of the Left Panel (A) so that it hooks under the "L" shape of the Back Panel (B).
- C. Adjust as needed so that the screw holes line up. Using a Philips head screwdriver and two, Round Head Screws (4), secure the two panels together at the middle and bottom points, as shown.

PLEASE NOTE:

Do not put a screw in the top hole during this step. This will be completed in Step 4.

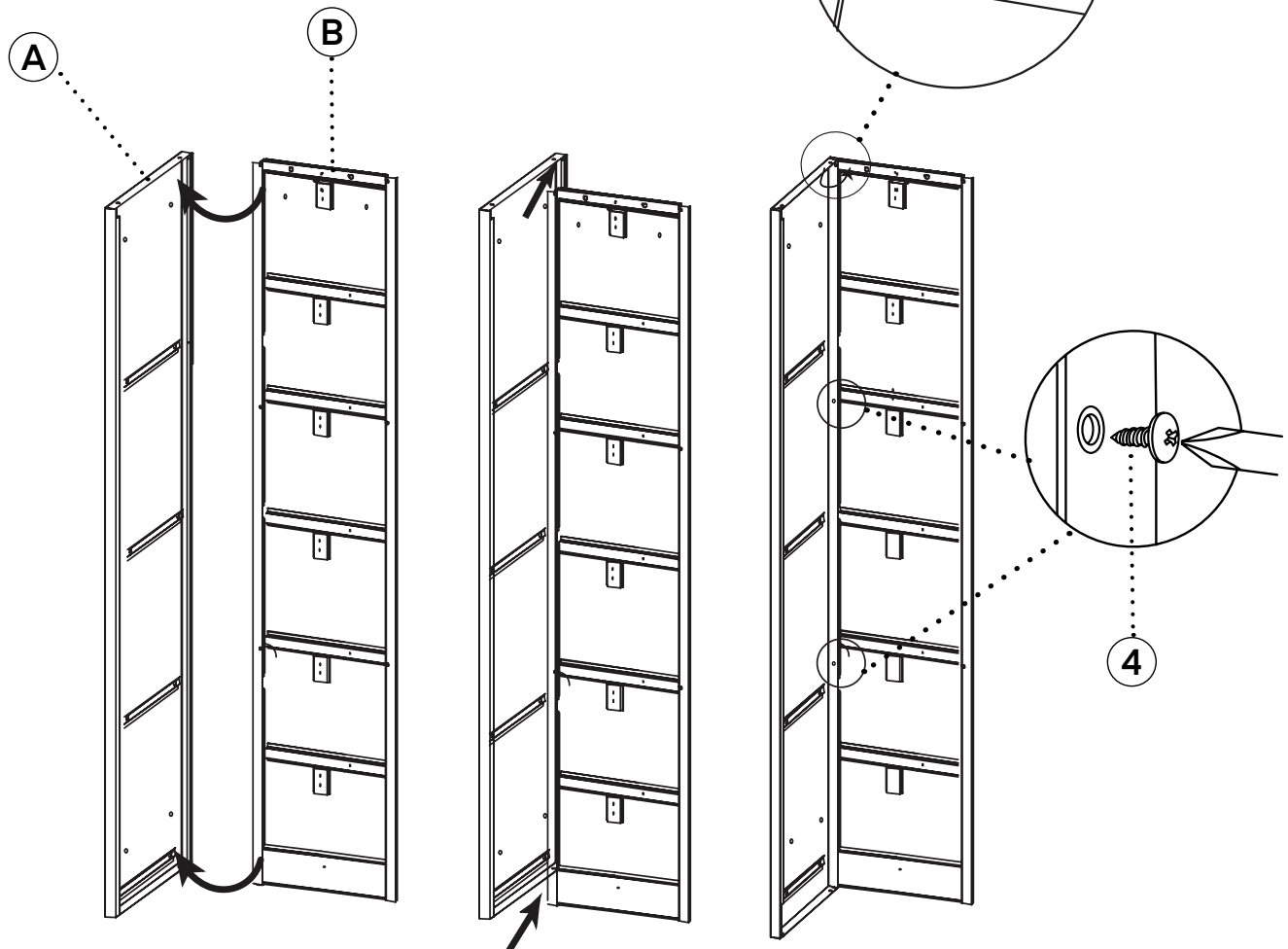

Step 2:

- A. Place the Right Panel (C) onto the right side of the Back Panel (B).
- B. Line it up so the "C" shape of the Right Panel (C) hooks under the "L" shape of the Back Panel (B), as described in Step 1.
- C. Adjust as needed so that the screw holes line up. Using a Philips head screwdriver and two, Round Head Screws (4), secure the two panels together at the middle and bottom points, as shown.

PLEASE NOTE:

Do not put a screw in the top hole during this step. This will be completed in Step 4.

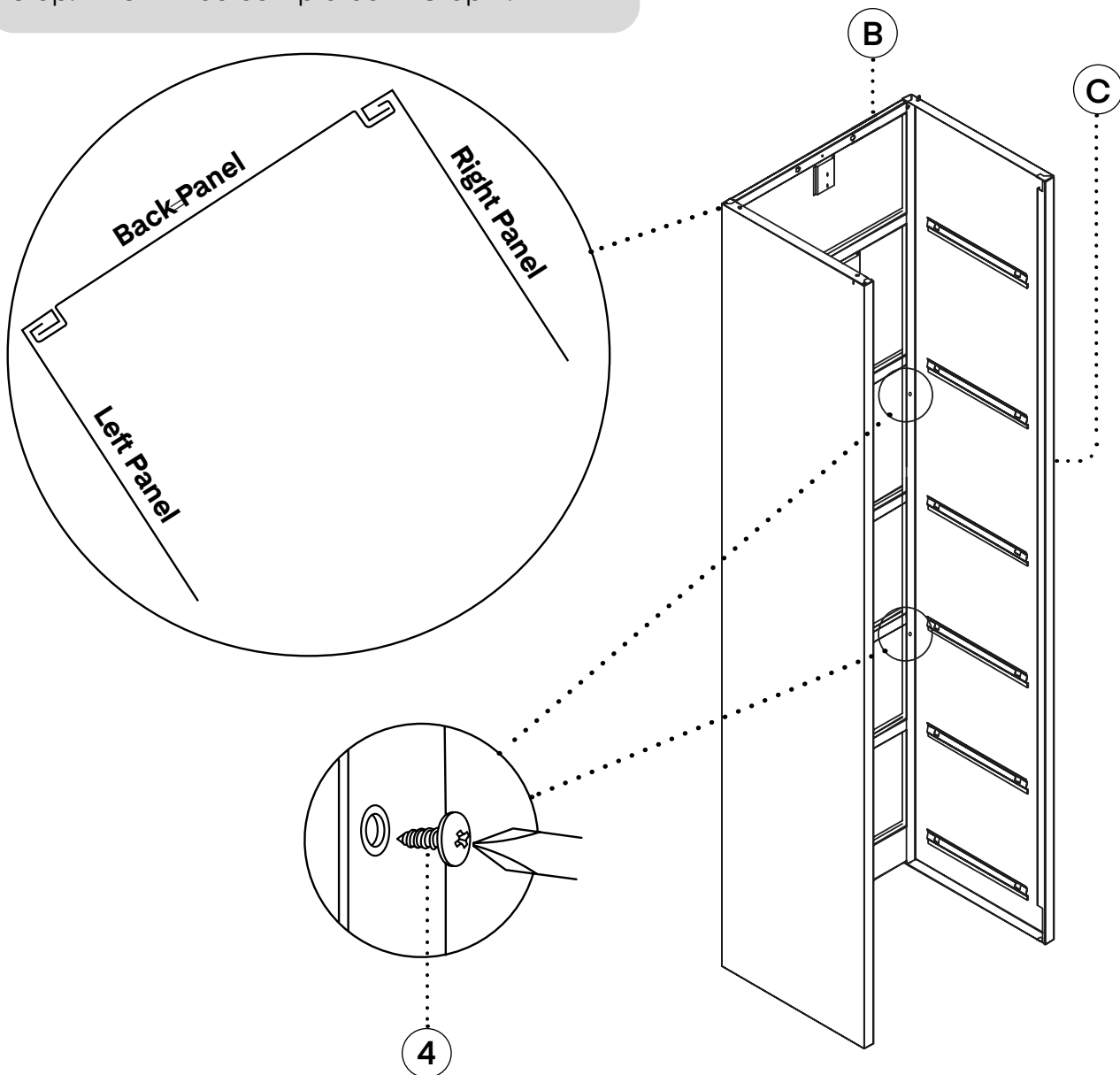

Step 3:

- A. To attach the Door Panel (D), move the panel into the locker at an angle so that it is completely inside of the enclosure.
- B. There is a pocket located at the top and bottom of each side panels into which the Door Panel (D) should insert.
- C. Pull the Door Panel (D) forward ensuring that the panel inserts into the pocket on each panel, as illustrated.
- D. Ensure the panel is pressed as far forward as possible so that the locker's front is flush.

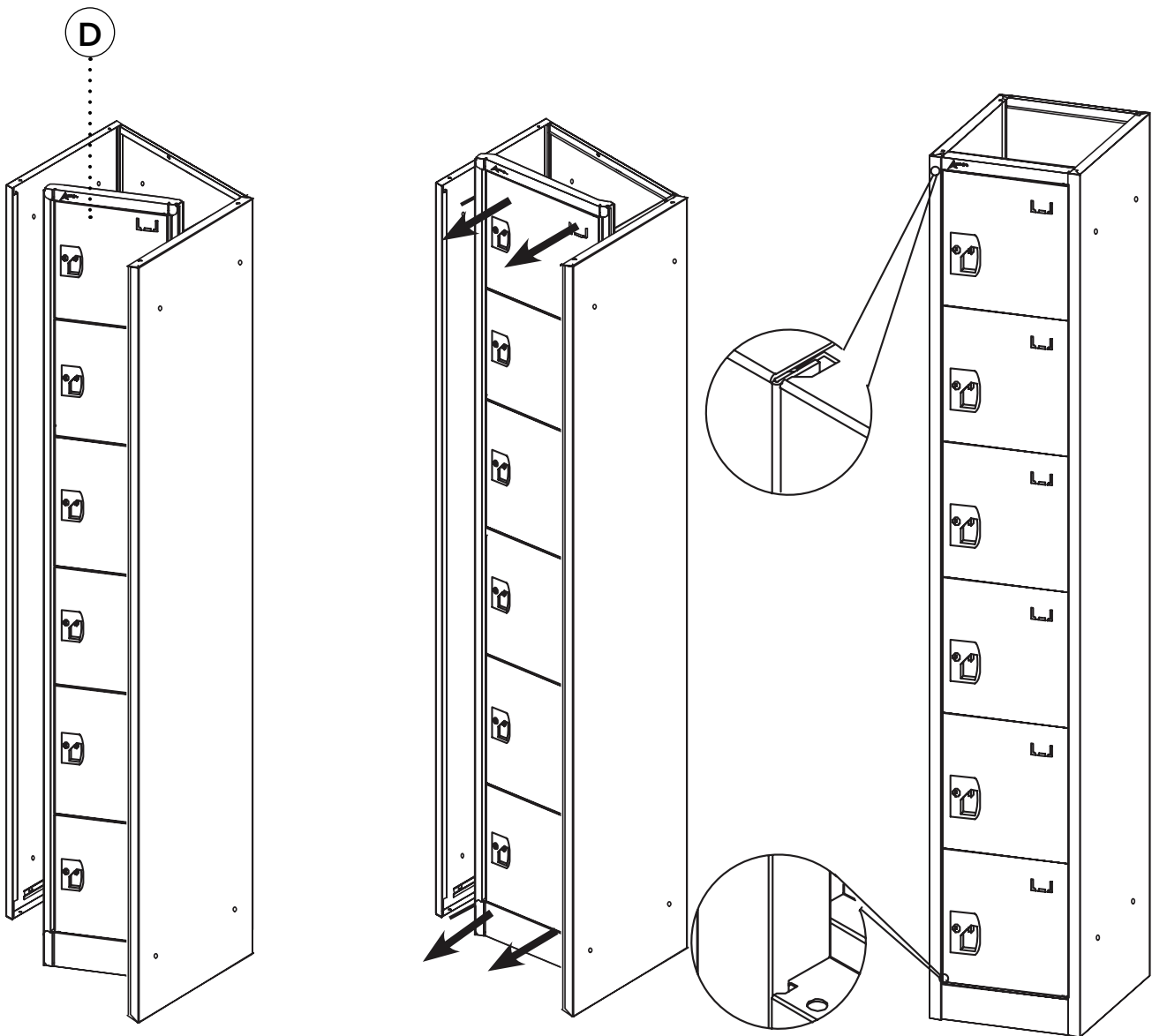

Step 4:

- A. Once the Door Panel (D) is attached, it is time to secure it by attaching the Top Panel (E), the Middle Panels (F) and the Bottom Panel (G).
- B. First, stand the structure up if it is laying on the ground.
- C. Unlock and open all of the doors on the Door Panel (D).
- D. Take the Top Panel (E), locate the two sideways "H's" on the edge of the panel.
- E. Take a flat head screwdriver, lightly press out the two little flaps of the "H" until they're at a 70 degree angle.
- F. With the sideways "H's" facing forward, insert the Top Panel (E) into the first cubby on an angle.
- G. Lift the panel up but, you must insert the front first, making sure those pushed out flaps catch in the interior inserts.
- H. Push the back of the panel all the way up.
- I. Secure the two back corner screw holes with two Round Head Screws (4).

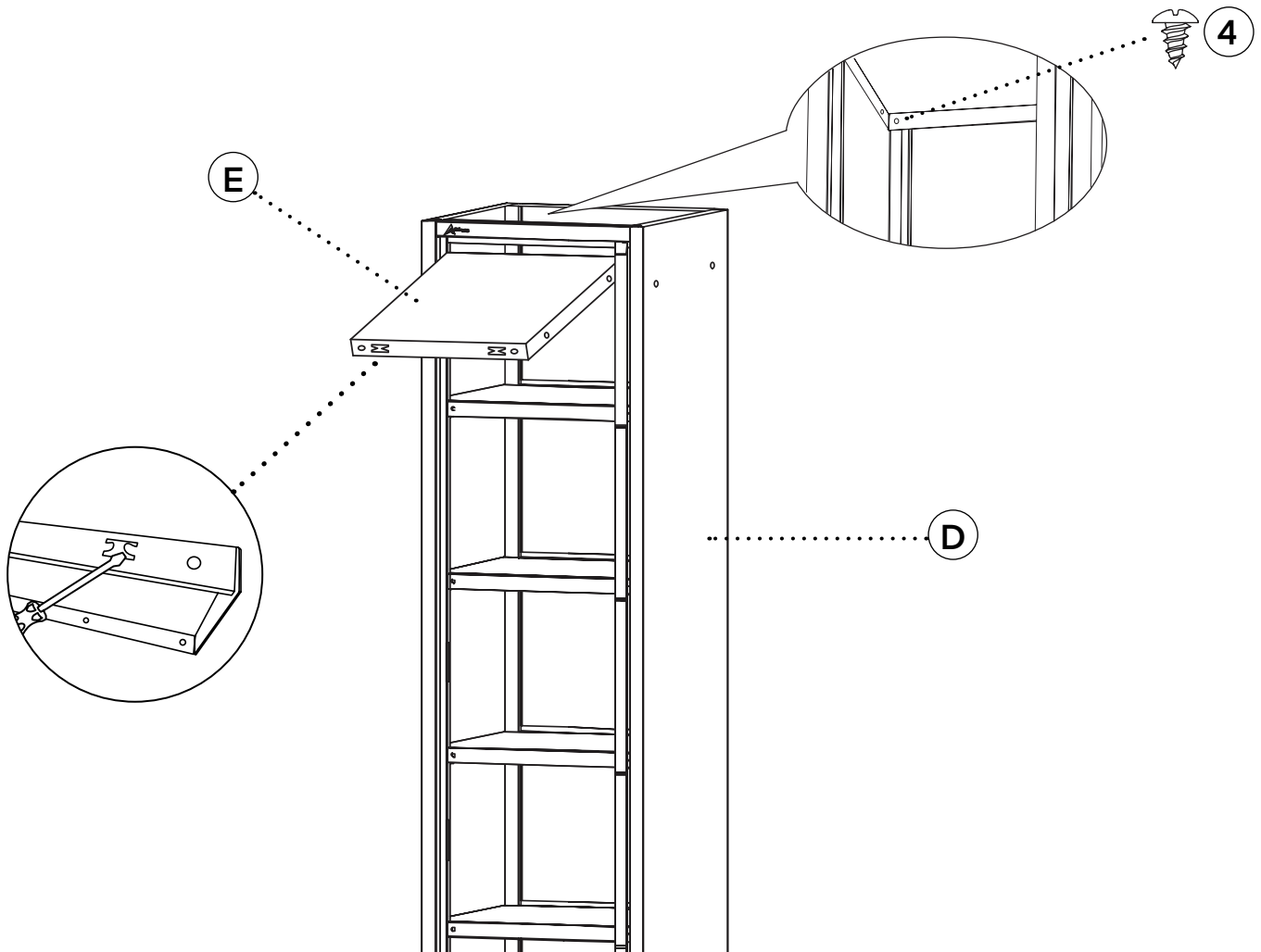

Step 5:

- A.** To install the Middle Panels (F), make sure the sideway 'H's" on the edge of the panels are facing forward before installing.
- B.** Place them inside of the cubbies, starting with the first, on an angle.
- C.** Push down firmly so that the sides catch on the tracks located on each of the side panels.
- D.** You may need to gently tap them until they are in place.
- E.** Repeat this for the remaining Middle Shelves (F) and the Bottom Shelf (G).
- F.** On all of the Middle Panels, secure a Round Head Screw (4) to the middle screw hole, located under each panel.
 - a.** You will have two screw holes, one at each corner, that will not be utilized.
- G.** To install the Bottom Panel (G), repeat the above steps. When it is time to access the screw hole, lay the locker down, and locate the middle screw hole under the Bottom Panel (G).
- H.** Insert a Round Head Screw (4) and tighten until secure.

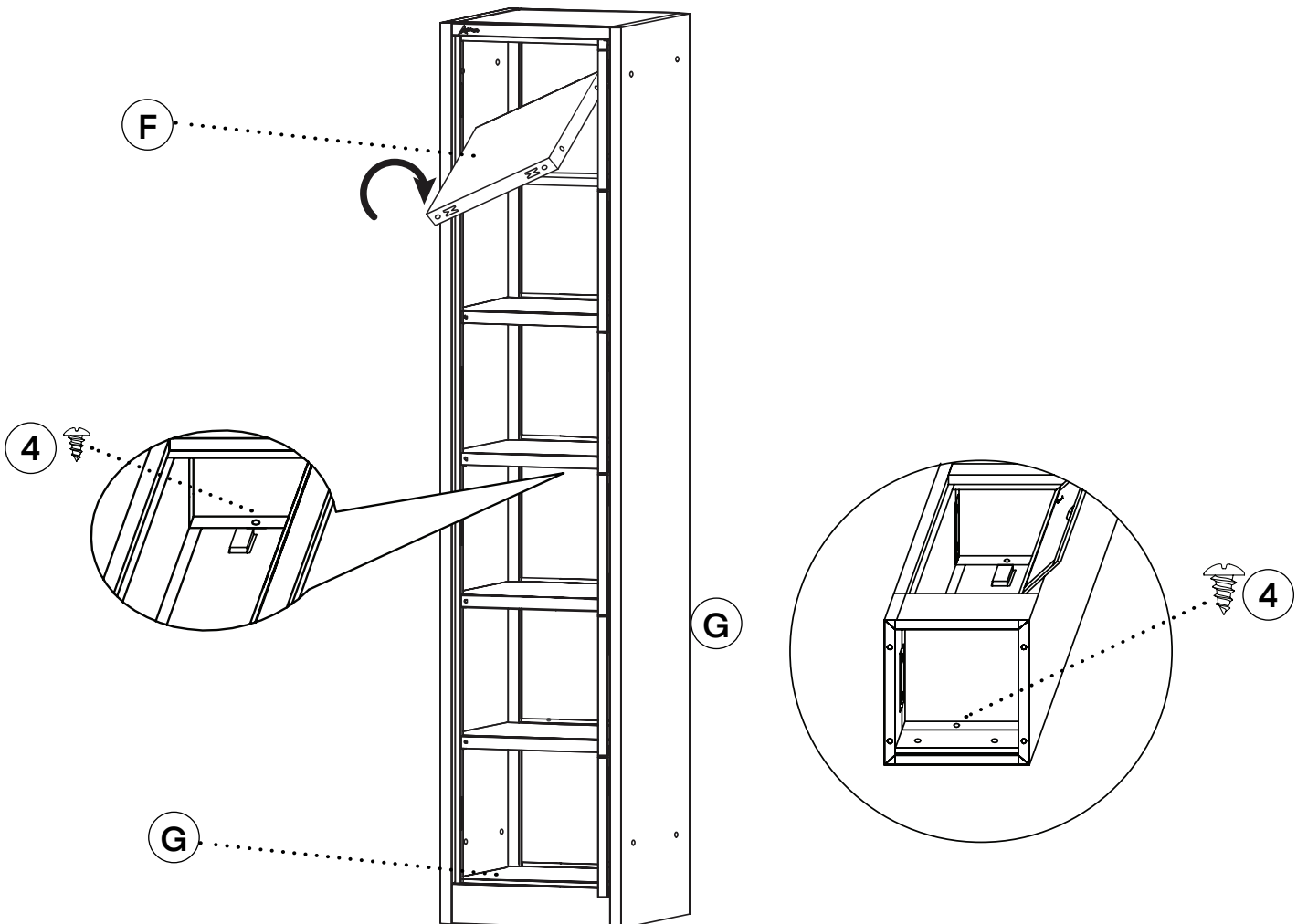

Step 6:

- A.** Attach the Double Hooks (6) to the Back Panel (B) of each cubby.
- B.** Insert two Round Head Screws (4) into each Double Hook (6) and secure using a Philips head screwdriver.

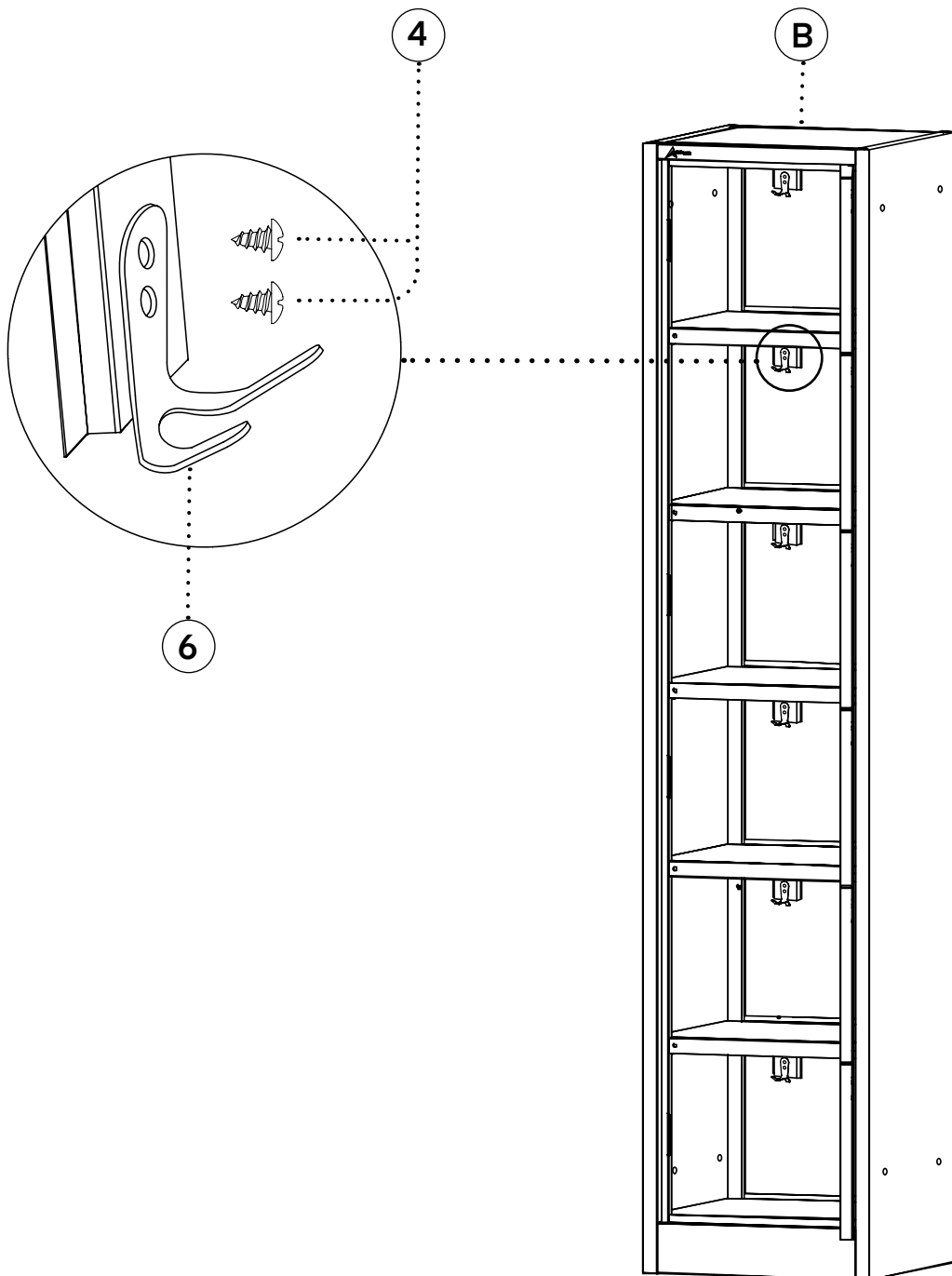

Installation Instructions

Multiple Locker Units

- A.** If you are using multiple locker units, secure them to each other for safety and security.
- B.** Set the lockers next to each other. Ensure the mounting holes towards the top of the Right Panel (C) of the left locker line up with the corresponding mounting holes on the Left Panel (A) of the right locker.
- C.** Insert the included Bolt (1) through the mounting holes on both lockers as shown. Secure the Bolt (1) with the included Nut (3) and Washer (2) on the other side.
- D.** Make sure you Bolt (1) the lockers together through both the front and back mounting holes. Repeat for each locker unit.

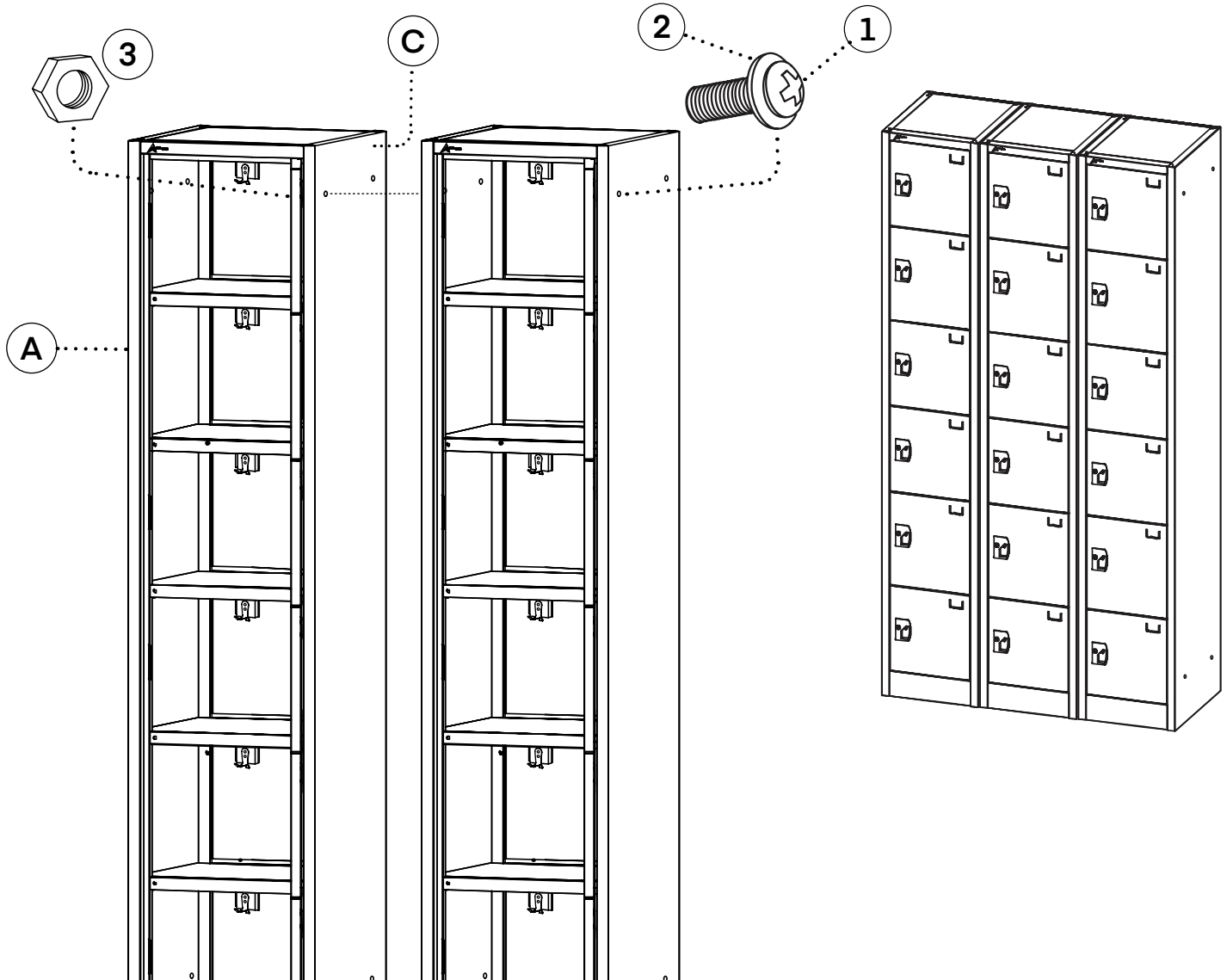

Mounting Locker Units

- A. There are two holes near the top of the Back Panel (B) of your locker.
- B. Place your locker where you want to install it. Using a pencil, mark the location of each of these holes on the wall.
- C. Remove the locker(s) from the wall. In the marked locations, drill a hole large enough for the Wall Anchors (5) (Make sure you don't drill it too large!)
- D. Using a Phillips screwdriver, twist each of the Wall Anchors (5) through the back of the locker and into the holes in the wall. Hand tightening is recommended; using a drill could damage the hole.

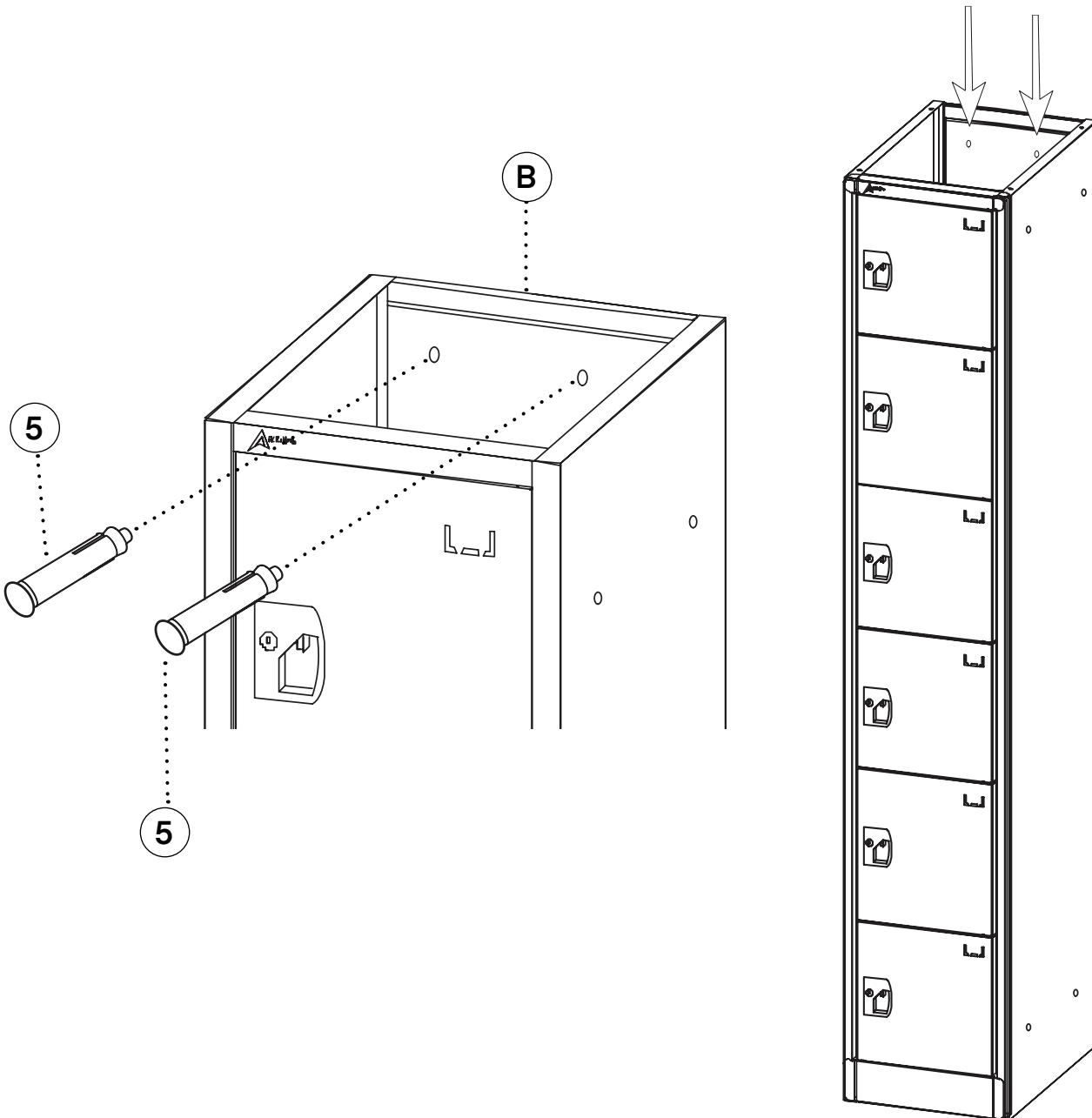

Warranty

1. Adir Corp (the "Company" or "Tiger Companies") warrants to the purchaser that the product will be free from defects in workmanship and materials for a period of 1 year from the date of purchase. The warranty period is not extended if we repair, replace, exchange, or provide a refund for the product (as determined in our sole discretion). We may change the availability of this limited warranty at our discretion, but any changes will not be retroactive.
2. These warranties are not assignable or transferable to any other person, including, without limitation, any subsequent owner or other transferee of the product.
3. This Warranty does not apply to: (a) damage caused by misuse, tampering, abuse, neglect, or accident; (b) damage caused by improper installation, modification, or service; (c) alteration of the serial number; or (d) use that violates the instructions furnished by the Company will void this warranty.
4. The sole responsibility of the Company shall be limited to (a) the repair or replacement (in its sole discretion) of any component of the product which fails to conform to this; (b) a refund the purchase price of such product (in its sole discretion), at no cost to the purchaser for the period of the warranty, or (c) an exchange for a similar product, comparable in function and price.
5. Contact the Company directly at 1-(800)-805-1790 to obtain service under this warranty. If it becomes applicable to send a defective product to the Company, a Return Authorization Number must first be obtained from the Company. In order to obtain service under this warranty, purchaser may be required to provide the Company with the following items (a) proof of purchase, (b) photographs and or videos (of the damage, and (c) a written testimonial describing the defect.
6. Products shipped without prior Return Authorization and Return Authorization Number may not be accepted, and the Company will not be responsible for their disposition and/or cost of return to the owner.
7. The Company will not assume any responsibility for any loss or damage incurred in shipping and or delivery.
8. The product(s) must be returned within 14 calendar days of receiving the return authorization from the Company and must include the original proof of purchase for the warranty to be honored.
9. Any implied warranties that the purchaser may have are limited to the duration of the warranties described above. There are no further warranties that extend or apply beyond the face hereof, and the Company expressly disclaims and excludes any and all warranties of merchantability or fitness for a particular purpose. Some states do not allow limitations on how long an implied warranty lasts, so the above limitation may not apply to you.
10. THE REMEDIES DESCRIBED ABOVE ARE YOUR SOLE AND EXCLUSIVE REMEDIES AND THE COMPANY'S ENTIRE LIABILITY FOR ANY BREACH OF THIS LIMITED WARRANTY. OUR LIABILITY SHALL UNDER NO CIRCUMSTANCES EXCEED THE ACTUAL AMOUNT PAID BY YOU FOR THE DEFECTIVE PRODUCT, NOR SHALL WE UNDER ANY CIRCUMSTANCES BE LIABLE FOR ANY CONSEQUENTIAL, INCIDENTAL, SPECIAL OR PUNITIVE DAMAGES OR LOSSES, WHETHER DIRECT OR INDIRECT. SOME STATES DO NOT ALLOW THE EXCLUSION OR LIMITATIONS OF INCIDENTAL OR CONSEQUENTIAL DAMAGES, SO THE LIMITATION MAY NOT APPLY TO YOU.
11. This warranty gives you specific legal rights, and you may also have additional rights which vary from state to state.

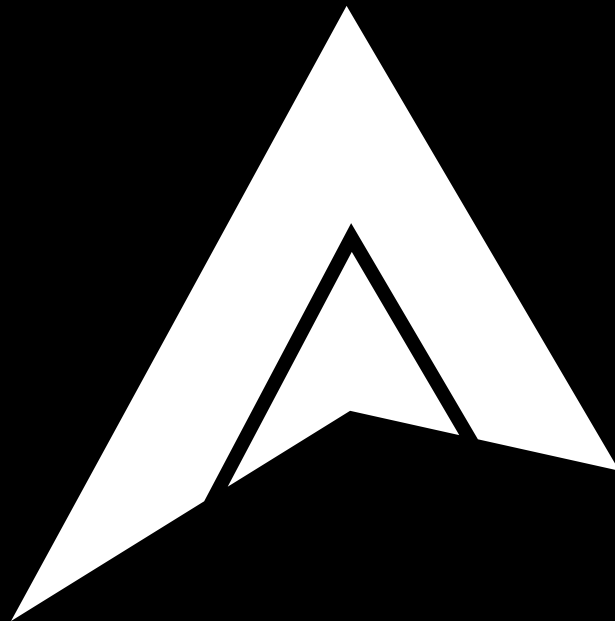

ADI629-206-SERIES

© 2023 AdirCorp

adircorp.com