

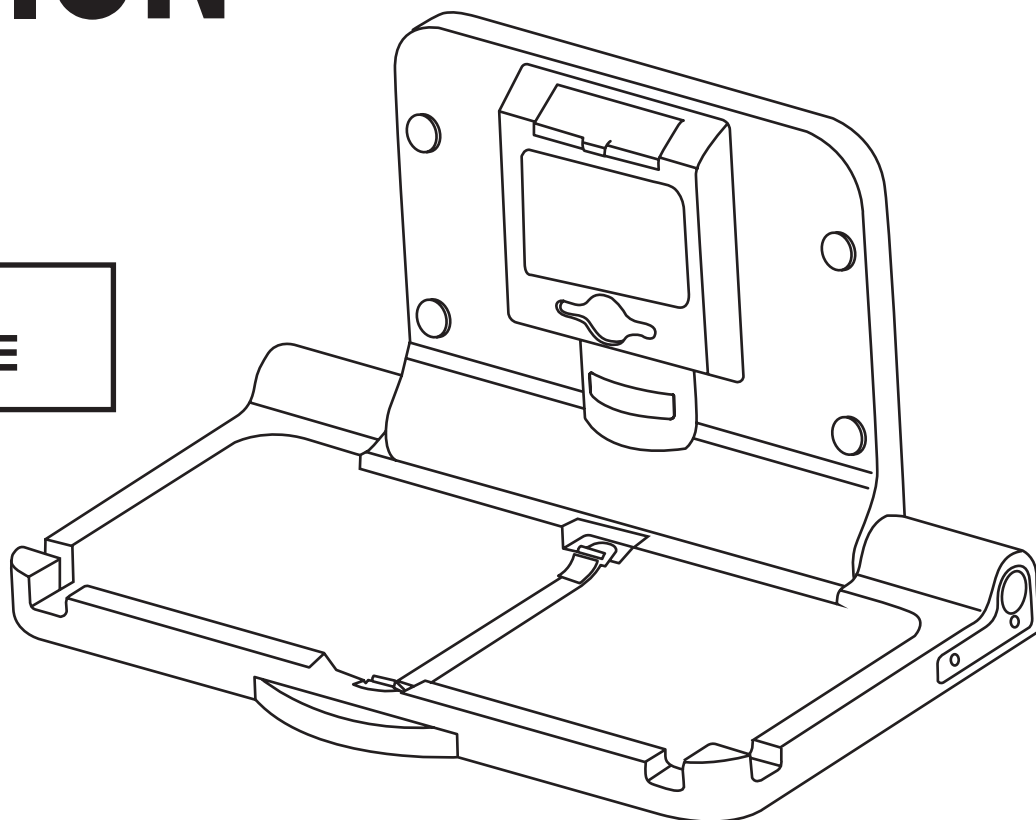

HORIZONTAL DIAPER CHANGING STATION

ALP411-E-SERIES
USER GUIDE





THANK YOU FOR YOUR PURCHASE.

Known in the industry for excellent products, Alpine Industries is a manufacturer of innovative, solution-based products for the commercial and institutional markets worldwide.

Combining commitment to the customer, design innovation and skilled, dedicated workforces, they have produced a range of products that are an essential part of every commercial facility. Every product is designed to the highest standards, enabling you to get your requirements done in a reliable and cost-effective way.



Table of Contents

- 1** Parts Included
- 2** Hardware Bag
- 3** Installation Instructions
- 9** Operation Instructions
- 10** Maintenance and Cleaning
- 11** Limited Warranty

Parts Included

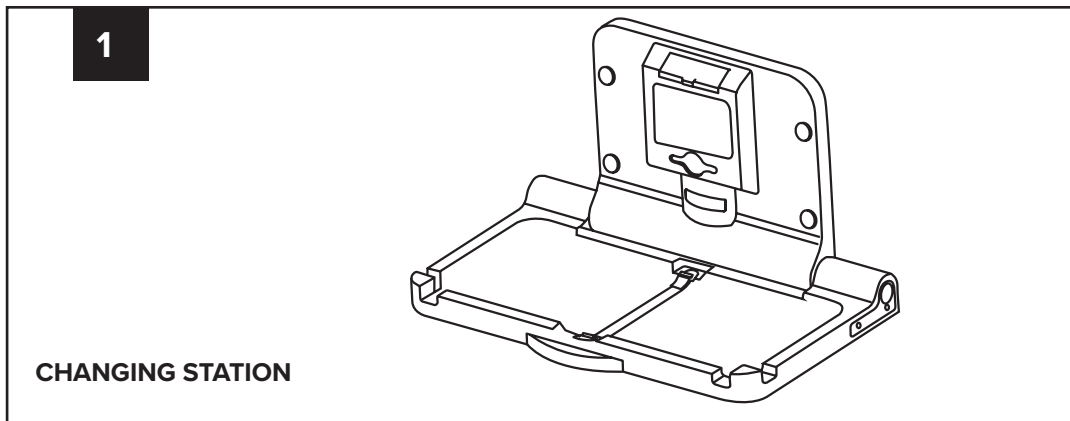

Tools Required (Not Included)

Adult Installation Required

- Level
- Measuring Tape
- Power Drill with 7/32", 1/8" and 1/2" masonry bits.
- Power screwdriver with bull nose Philips bit.

CAUTION:

- **Read all instructions before assembly of Diaper Changing Station.**
- **Unpack carton and identify all parts**

Hardware

A



3" WOOD SCREWS (4)

B

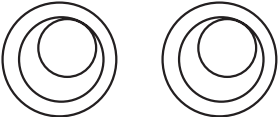

3/4" FINISHING WASHERS (4)

C

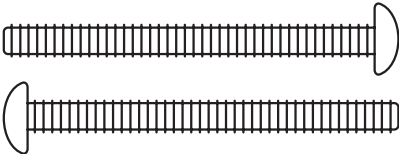

3" MACHINE SCREWS (2)

D

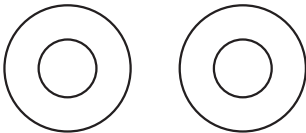

3/4" FLAT WASHERS (4)

E

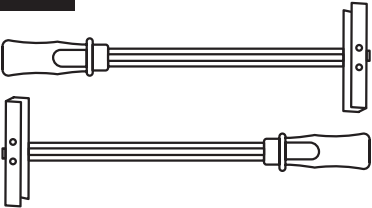

TOGGLE ANCHORS (2)

F

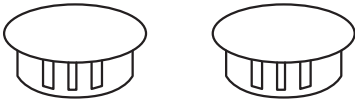

1 1/4" CAPS (4)

Installation Instructions



WARNING:

- One wall stud **MUST** be located and **USED** for at least one side of the diaper changing station.
- The diaper changing station **CANNOT** be heavier than the anchors or walls they are attached to.
- It **MUST** be firmly secured to support the additional weight of a child.
- Contact an architect or building contractor for further questions.

STEP 1:

A. Locate the wood stud where the left side of Changing Station (1) will be mounted to the wall.

STEP 2:

A. Measure up 42" (107cm) from the floor and mark the wall; this locates the top left attachment hole's position.

NOTE: Mark on wall **MUST** be in the center of the wood stud.

STEP 3:

A. Align the hole in the top left corner of Changing Station (1) with the mark on the wall and hold it in place.

STEP 4:

- A. Using a level and measuring tape, mark the remaining three (3) holes.
B. After marking holes, set the Changing Station (1) down on the ground.

STEP 5:

- A. Use a power drill and appropriate bit to drill four (4) holes in the wall.
B. This may require two (2) people.

NOTE 1: FOR WOOD STUDS:

- If the finished wall surface is tile or masonry over wood studs, use a 7/32" masonry bit for the pilot hole until you hit the wood stud, then change it to a 1/8" bit.
- Use Wood Screws (A), finishing Washers (B), and Flat Washers (D) (See Figure A on page 4).

Installation Instructions

FIGURE A

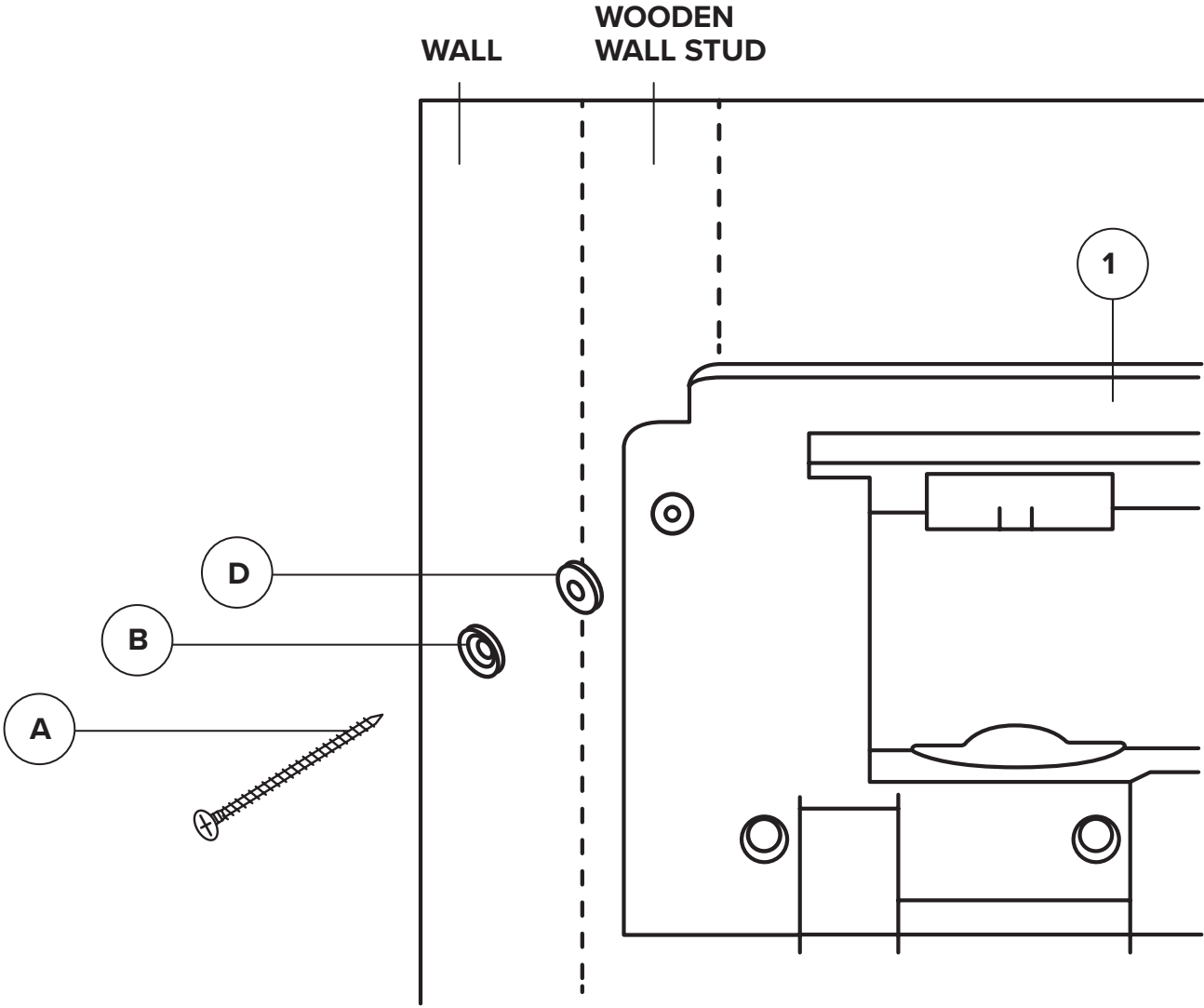

Installation Instructions

NOTE 2: FOR USE WITH TOGGLE ANCHORS (E):

- If the finished wall surface has wood studs that are not 16" on center, has metal studs, or has an underlying surface of concrete block, use ½" bit.
- Use Machine Screws (C) and Flat Washers (D) (See Figure B on page 6).
- For holes NOT located in a wood stud, Toggle Anchors (E) MUST be used (See Figure C on page 7). See "Using Toggle Anchors" section.

STEP 6:

- A. Align holes in Changing Station (1) with drilled holes and secure top left corner of Changing Station (1) to wall stud using the appropriate screw and washer.
- B. Continue to secure the three (3) remaining corners using the proper screws and washers as described in NOTE 1 or NOTE 2.

 **WARNING:**

ALL 4 OF THESE LOCATIONS MUST BE USED FOR SAFE INSTALLATION. THE LOWER HOLES ENSURE INSTALLATION THROUGH THE METAL BRACKETS.

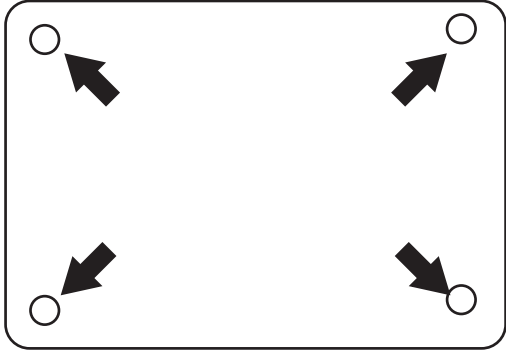

STEP 7:

- A. Ensure all four (4) screws are tight and snap the Caps (F) over the screw heads.

Installation Instructions

FIGURE B

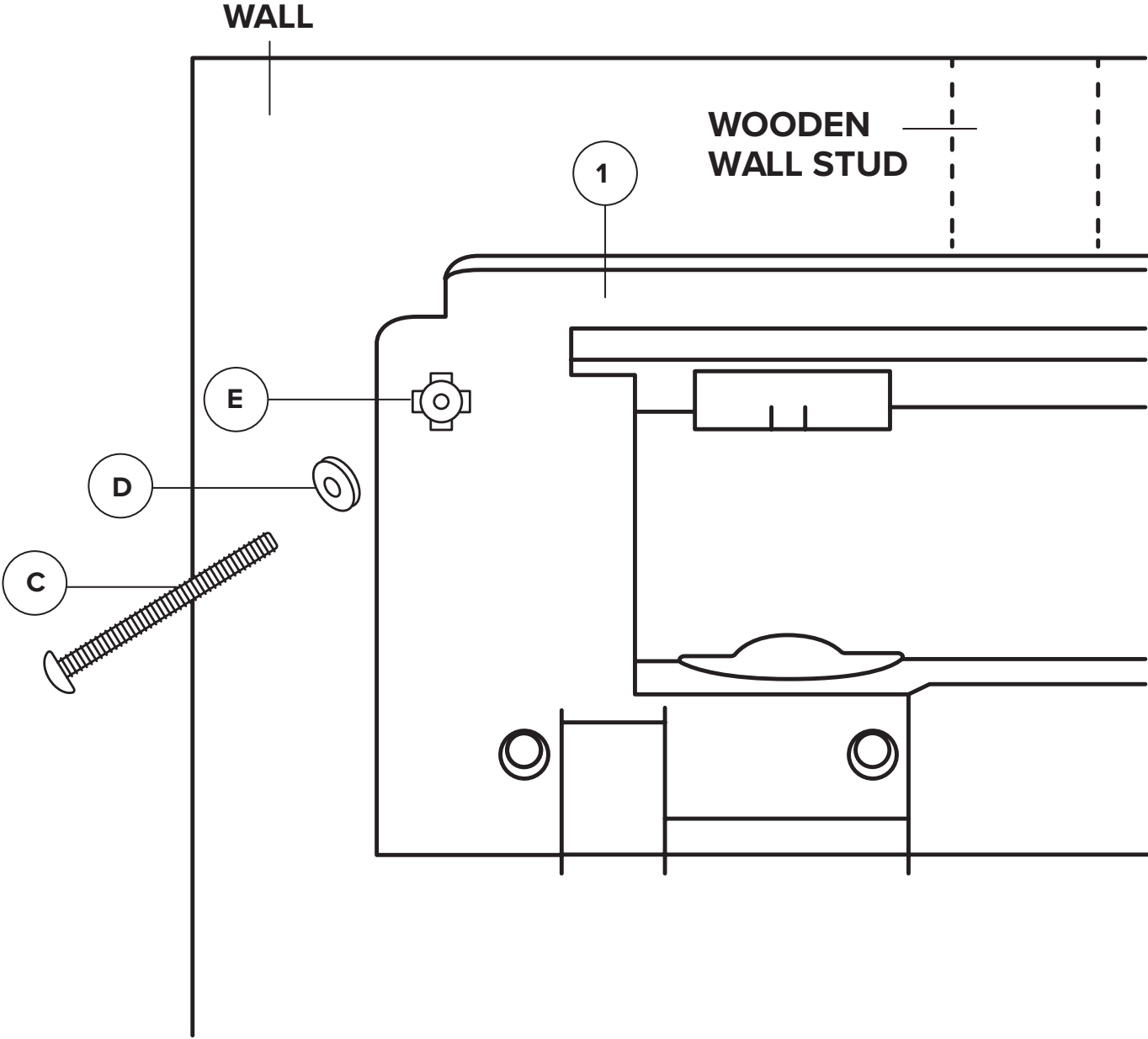

Installation Instructions

USING TOGGLE ANCHORS:

1. Insert the metal end of the Toggle Anchor (E) into the 1/2" hole.
2. Slide zip strip down snugly against the wall.
3. Snap off break-away pieces of Toggle Anchor (E) (See Figure C below).
4. Ensure all four (4) screws are tight and snap Caps (F) over screw heads.
5. Align holes on the Changing Station (1) with Toggle Anchors (E) and secure top left corner of the Changing Station (1) to the wall using Machine Screws (C) and Flat Washers (D).
6. Continue to secure the three (3) remaining corners using Machine Screws (C) and Flat Washers (D).

FIGURE C

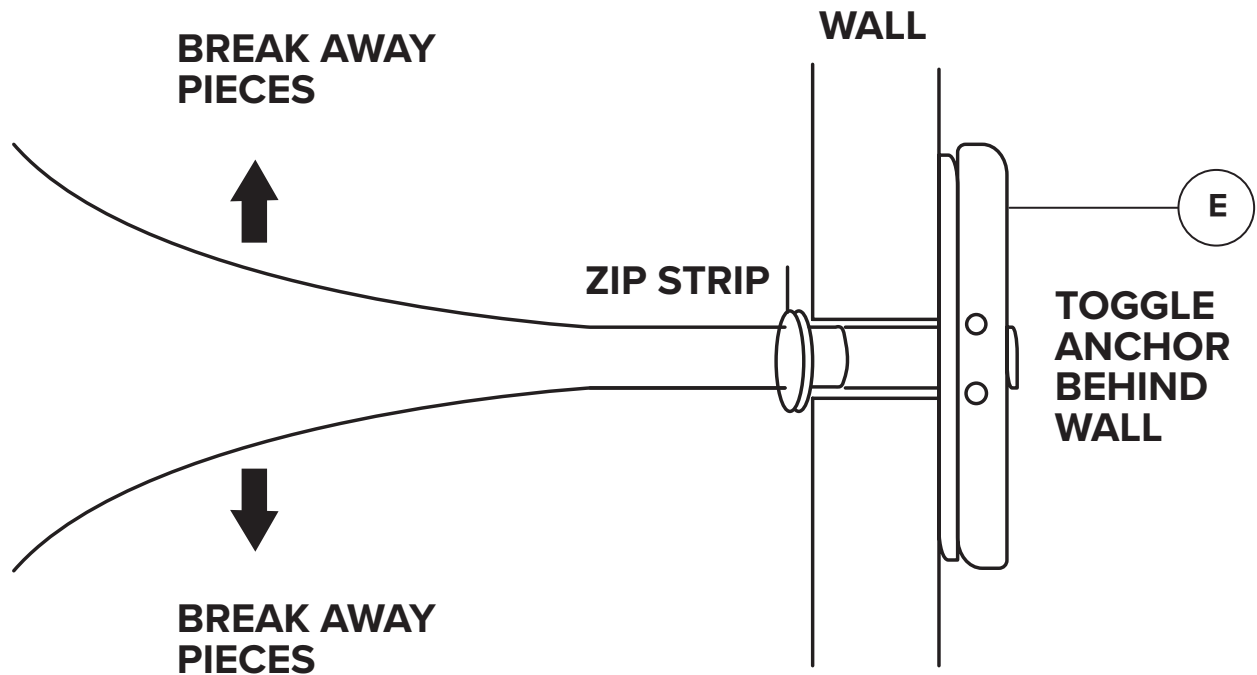

Installation Instructions

RECOMMENDED BLOCKING

- 1. If the walls do not have studs on center, additional blocking is necessary (See Figure D below).
- 2. Contact an architect or building contractor to make sure the blocking is adequate and complies with building codes.

FIGURE D

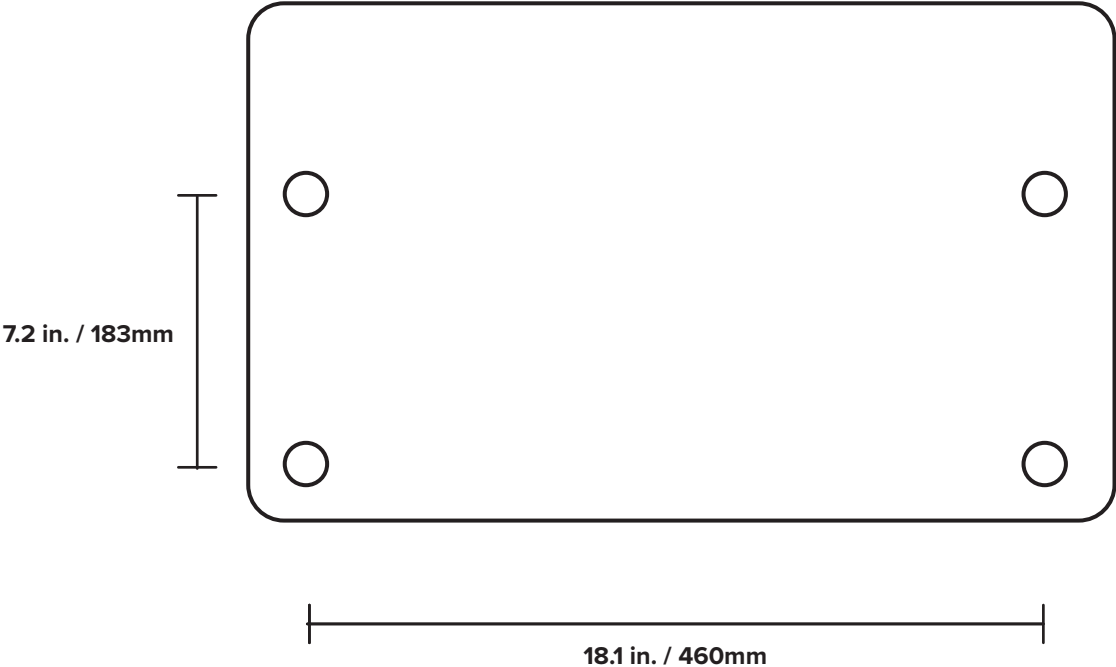

Operation Instructions

1. Rotate base downward and place the infant on top of the changing surface.
2. Use restraint system as described below. After the child has been changed, remove the restraint system, and rotate the base back up against the wall.

USING THE RESTRAINT SYSTEM:

1. Place the child so that the restraint strap is located at the abdomen.
2. Rotate the top of the buckle upward and insert the strap in the buckle.
3. Pull the strap through the buckle until snug against the infant.
4. Rotate the top of the buckle downward to lock the strap into place.
5. Slide the yellow locking tab over top of the buckle.
6. Reverse these steps to loosen the strap.

Maintenance and Cleaning

1. Clean by using a damp cloth with mild soap or mild multi-purpose cleaner.
2. Do not use any strong chemical cleaners or cleaning agents that may be hazardous to children.
3. Check all hardware and components monthly or as required to ensure the hardware is tight and there are no missing or damaged pieces.
4. Take unit out of service if any element is missing or damaged and contact customer service to order replacement parts. Do not substitute parts



WARNING:

- **A child should never be left unattended.**
- **Always use a restraint system to avoid serious injury from fall or sliding out.**
- **The weight limit is 50 pounds (22.7 kg): avoid adding parcels/packages/ accessories to the unit or the bag hooks that exceed the weight limit.**
- **It may cause unit to become unstable or hazardous conditions to occur.**

Limited Warranty

1. Adir Corp (the "Company" or "Tiger Companies") warrants to the purchaser that the product will be free from defects in workmanship and materials for a period of 90 days from the date of purchase. The warranty period is not extended if we repair, replace, exchange, or provide a refund for the product (as determined in our sole discretion). We may change the availability of this limited warranty at our discretion, but any changes will not be retroactive.
2. These warranties are not assignable or transferable to any other person, including, without limitation, any subsequent owner or other transferee of the product.
3. This Warranty does not apply to: (a) damage caused by misuse, tampering, abuse, neglect, or accident; (b) damage caused by improper installation, modification, or service; (c) alteration of the serial number; or (d) use that violates the instructions furnished by the Company will void this warranty.
4. The sole responsibility of the Company shall be limited to (a) the repair or replacement (in its sole discretion) of any component of the product which fails to conform to this; (b) a refund the purchase price of such product (in its sole discretion), at no cost to the purchaser for the period of the warranty, or (c) an exchange for a similar product, comparable in function and price.
5. Contact the Company directly at 1-(800)-805-1790 to obtain service under this warranty. If it becomes applicable to send a defective product to the Company, a Return Authorization Number must first be obtained from the Company. In order to obtain service under this warranty, purchaser may be required to provide the Company with the following items (a) proof of purchase, (b) photographs and or videos (of the damage, and (c) a written testimonial describing the defect.
6. Products shipped without prior Return Authorization and Return Authorization Number may not be accepted, and the Company will not be responsible for their disposition and/or cost of return to the owner.
7. The Company will not assume any responsibility for any loss or damage incurred in shipping and or delivery.
8. The product(s) must be returned within 14 calendar days of receiving the return authorization from the Company and must include the original proof of purchase for the warranty to be honored.
9. Any implied warranties that the purchaser may have are limited to the duration of the warranties described above. There are no further warranties that extend or apply beyond the face hereof, and the Company expressly disclaims and excludes any and all warranties of merchantability or fitness for a particular purpose. Some states do not allow limitations on how long an implied warranty lasts, so the above limitation may not apply to you.
10. THE REMEDIES DESCRIBED ABOVE ARE YOUR SOLE AND EXCLUSIVE REMEDIES AND THE COMPANY'S ENTIRE LIABILITY FOR ANY BREACH OF THIS LIMITED WARRANTY. OUR LIABILITY SHALL UNDER NO CIRCUMSTANCES EXCEED THE ACTUAL AMOUNT PAID BY YOU FOR THE DEFECTIVE PRODUCT, NOR SHALL WE UNDER ANY CIRCUMSTANCES BE LIABLE FOR ANY CONSEQUENTIAL, INCIDENTAL, SPECIAL OR PUNITIVE DAMAGES OR LOSSES, WHETHER DIRECT OR INDIRECT. SOME STATES DO NOT ALLOW THE EXCLUSION OR LIMITATIONS OF INCIDENTAL OR CONSEQUENTIAL DAMAGES, SO THE LIMITATION MAY NOT APPLY TO YOU.
11. This warranty gives you specific legal rights, and you may also have additional rights which vary from state to state.



ALP411-E-SERIES

© 2024 Alpine Industries
alpineindustries.com