

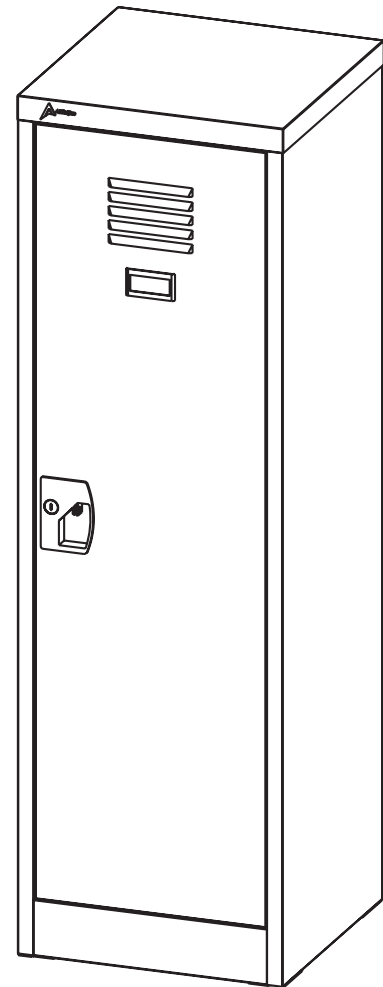

.....

# 48" Kids Locker

.....



**ADI629-01-SERIES  
USER GUIDE**



# Thank you for your purchase.

.....

**AdirOffice has a commitment to  
deliver quality and stylish office  
furniture and equipment.**

.....

We understand starting and maintaining a business is expensive enough. We can help you make it cost effective and beautiful. Plus, our expert team makes sure everything you need works as efficiently as possible.

# Table of Contents

- 1** Parts List
- 2** Assembly Instructions
- 11** Mounting Instructions
- 12** Limited Warranty

# Parts Included

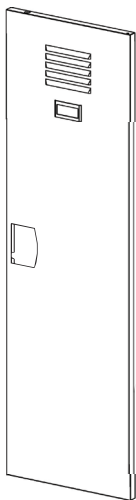

Door (1)

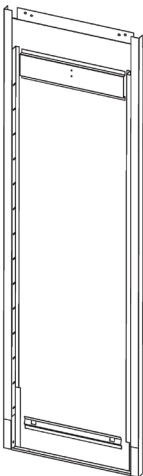

Left Side Panel (2)



Back Panel (3)

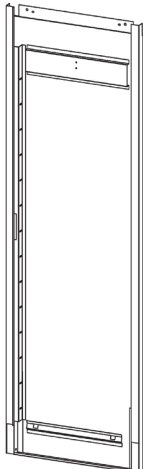

Right Side Panel (4)

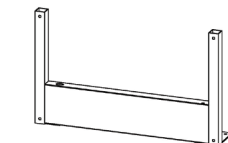

Front Leg (5)

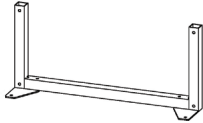

Back Leg (6)

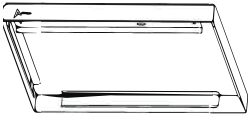

Top Panel (7)



Base (8)



2x Shelves (9)



4x Big Screws (A)



4x Small Screws (B)



Shelf Clips (C)

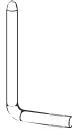

Large Hinge Pin (D)



Small Hinge Pin (E)

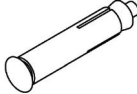

2x Wall Anchor (F)

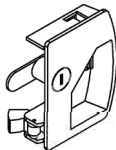

Lock (G)



Keys (H)



2x Double Hook (I)

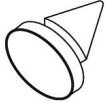

Rubber Buffer (J)

# Assembly Instructions

## STEP 1:

Turn the Left Side Panel (2) and the Right-Side Panel (4) upside-down. Insert the Back Leg (6) into the shorter holes of both side panels, apply pressure. Insert the Front Leg (5) into the deeper slots and apply pressure. Insert all four Big Screws (A) into the bottom of the legs.

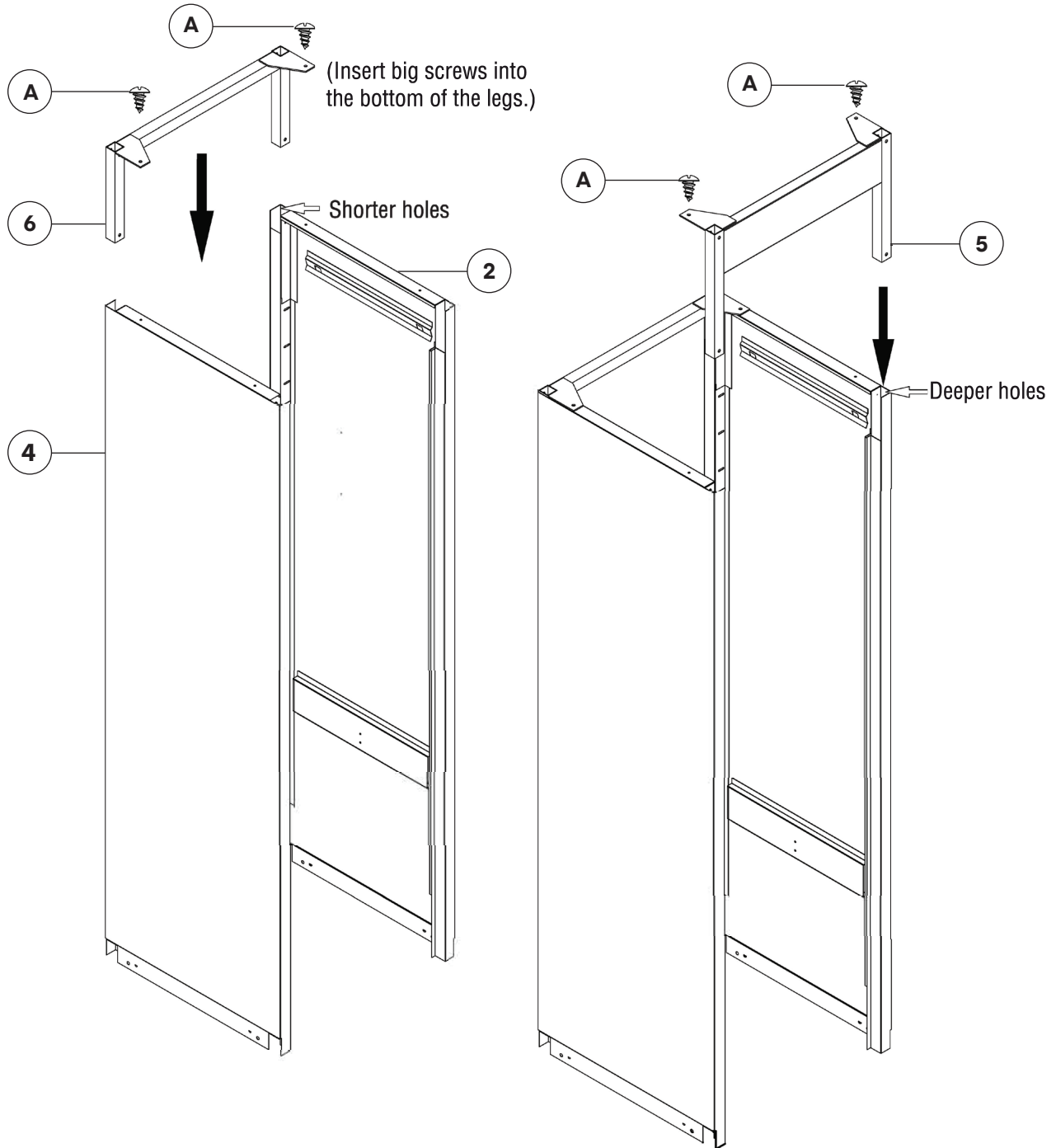

# Assembly Instructions

## STEP 2:

Flip the locker to the upright position and align the Back Panel (3) between Left Side Panel (2) and the Right-Side Panel (4).

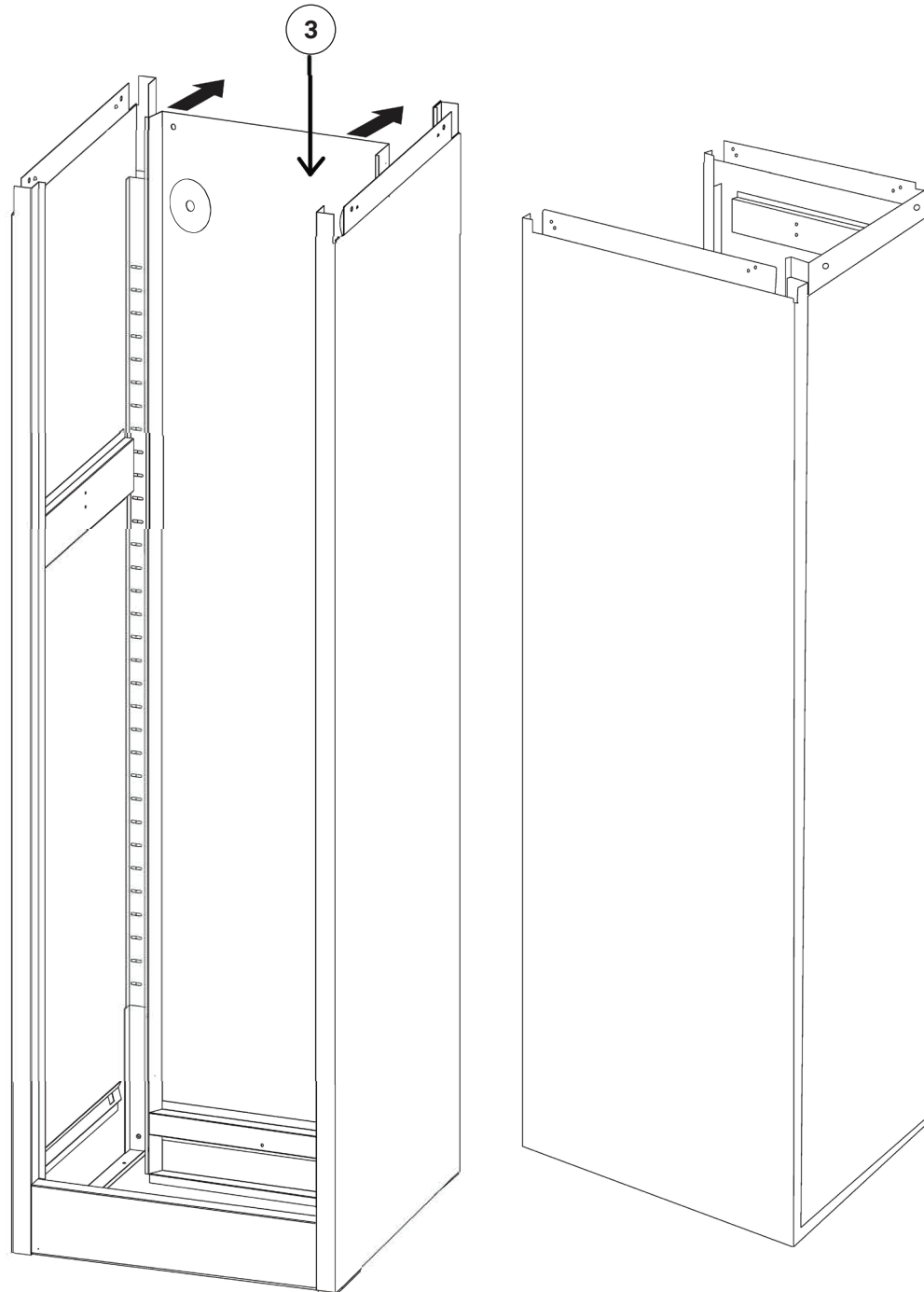

# Assembly Instructions

## STEP 3:

Insert the Top Panel (7) onto the locker. Ensure that the locker's edges are aligned with the lips found underneath the Top Panel (7). Push the top portion into place by applying some pressure. Make sure all edges snap in firmly.

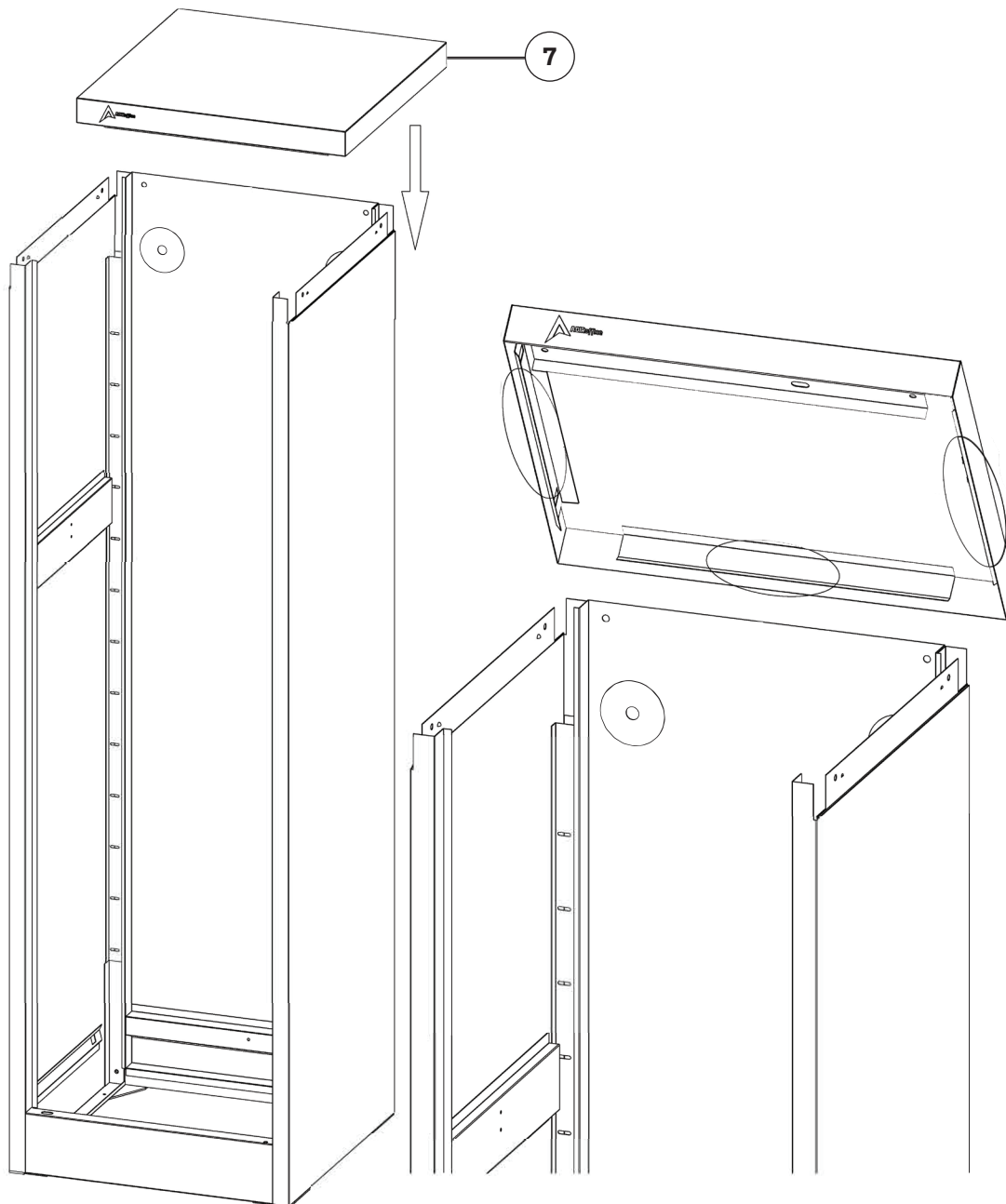

# Assembly Instructions

## STEP 4:

Insert the Small Hinge Pin (E) in the hole on the locker's bottom right side, as shown.

Place the Door (1) onto the Small Hinge Pin (E) in the at the bottom of the Door (1).

Next, take the Large Hinge Pin (D), insert it into the hole on the top of Door (1), and lock it into place by passing it through the slot on the Door (1).

Push the metal lever up, as shown, to secure your Large Hinge Pin (D) in place.

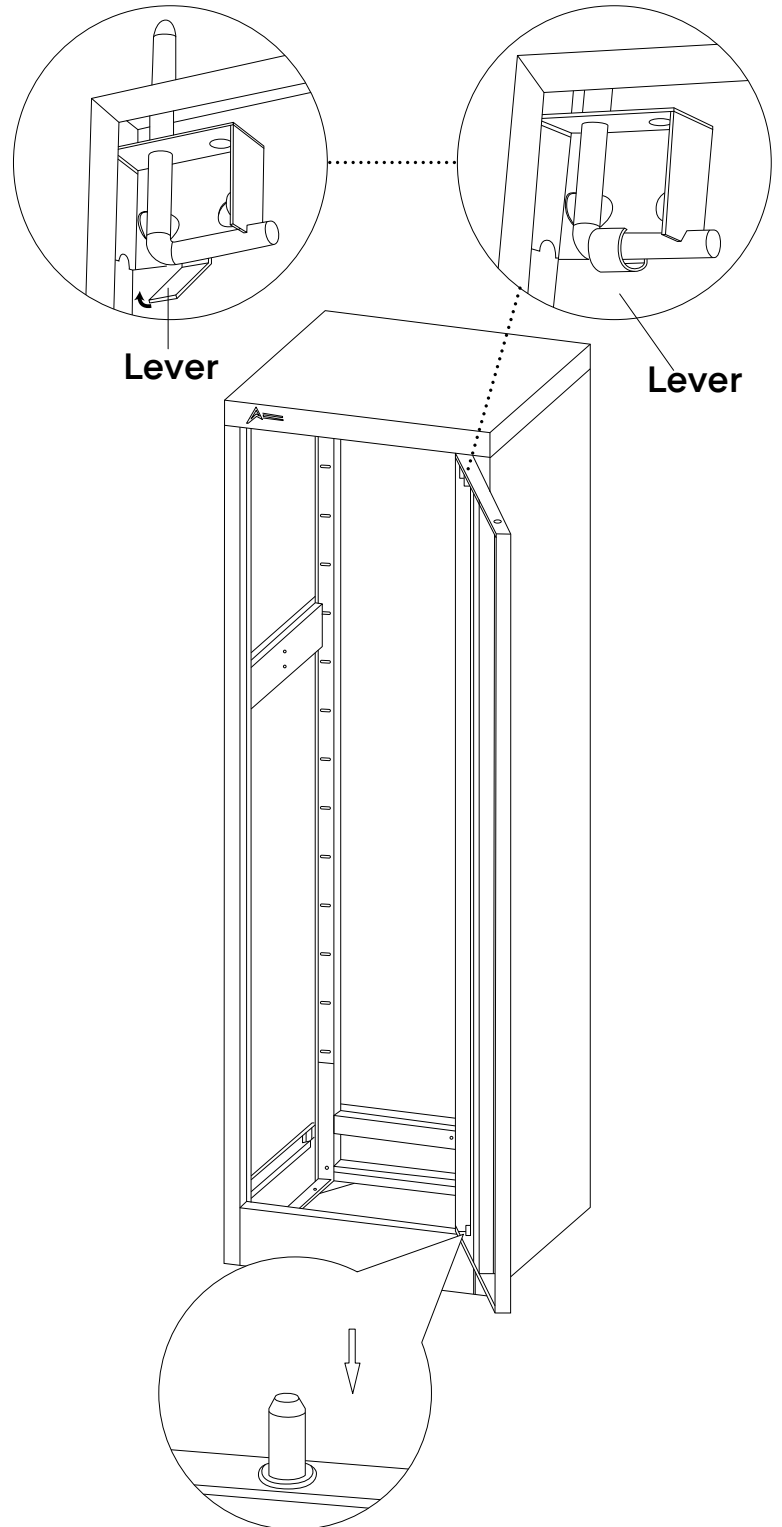



# Assembly Instructions

## STEP 5:

Insert Lock (G) in the Door (1), and make sure it snaps into place firmly.

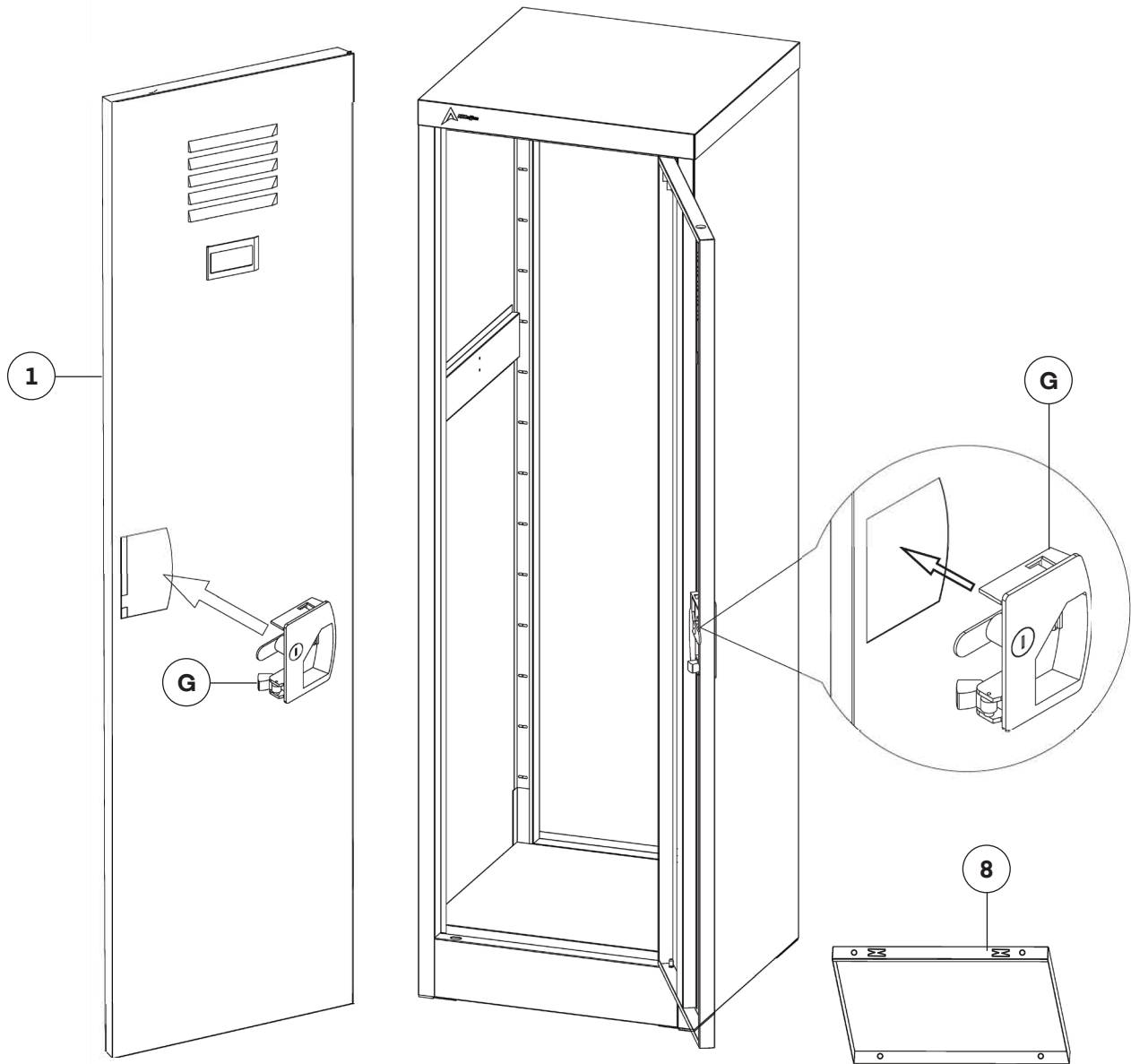

## STEP 6:

Insert the Base (8) into the locker by pressing down with edges pointing down and the smooth side up.

# Assembly Instructions

## STEP 7:

Attach the Double Hook (I) with the Small Screws (B).

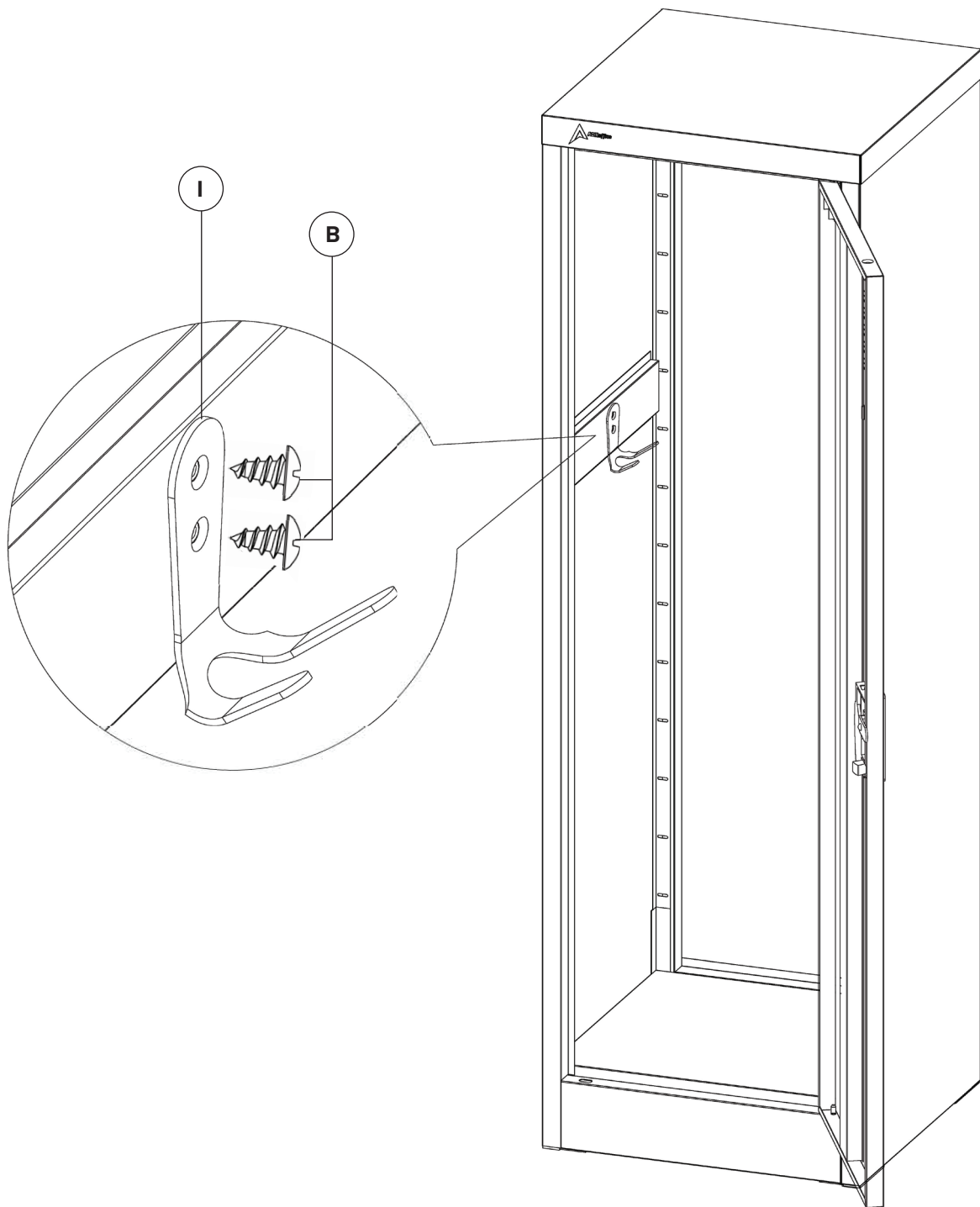

# Assembly Instructions

## STEP 8:

Insert the two Rubber Buffer's (J) in the top and bottom corners of the Door (1), as shown.

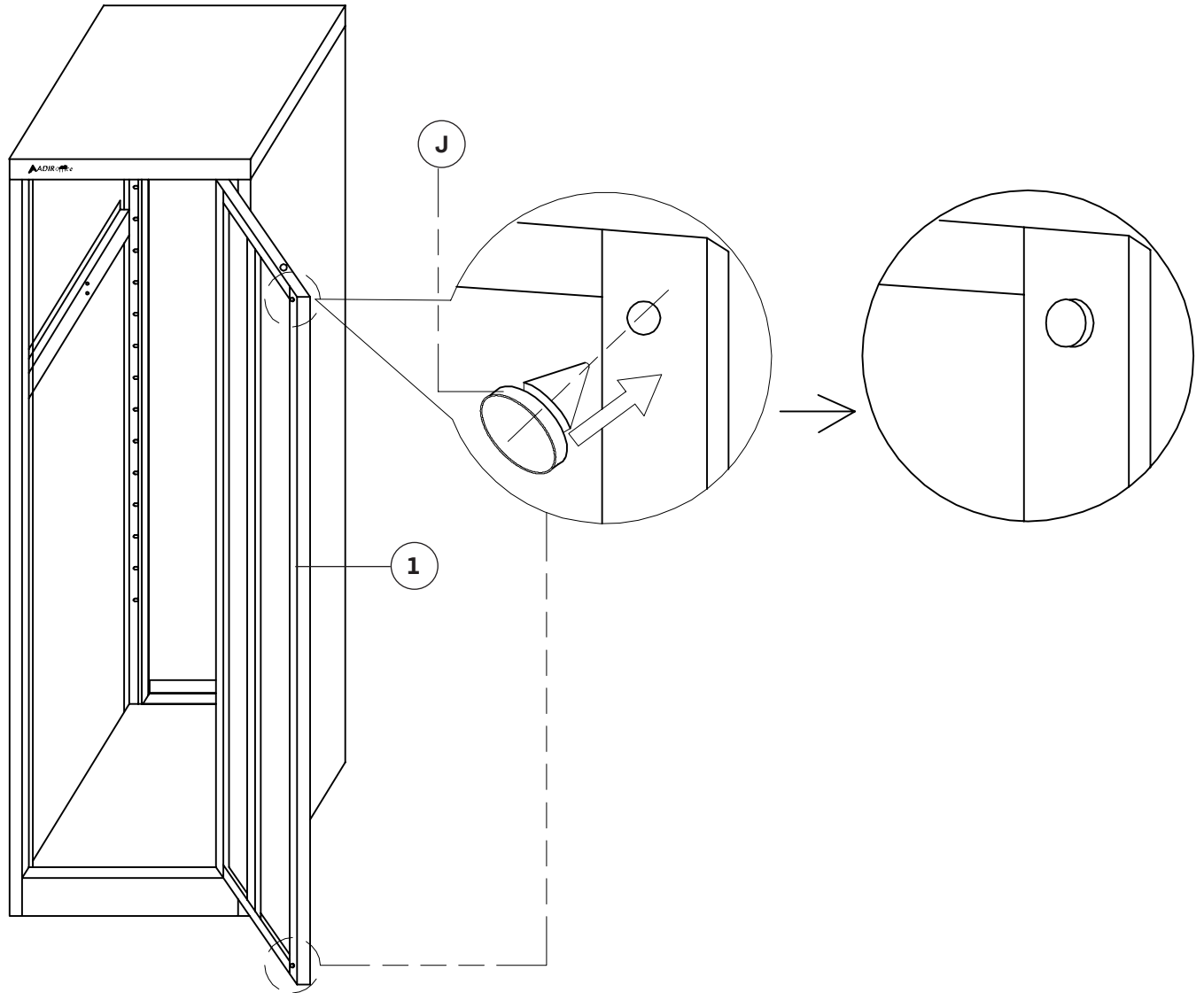

# Assembly Instructions

**STEP 9:**  
Insert the Shelf Clips (C) to the desired height.

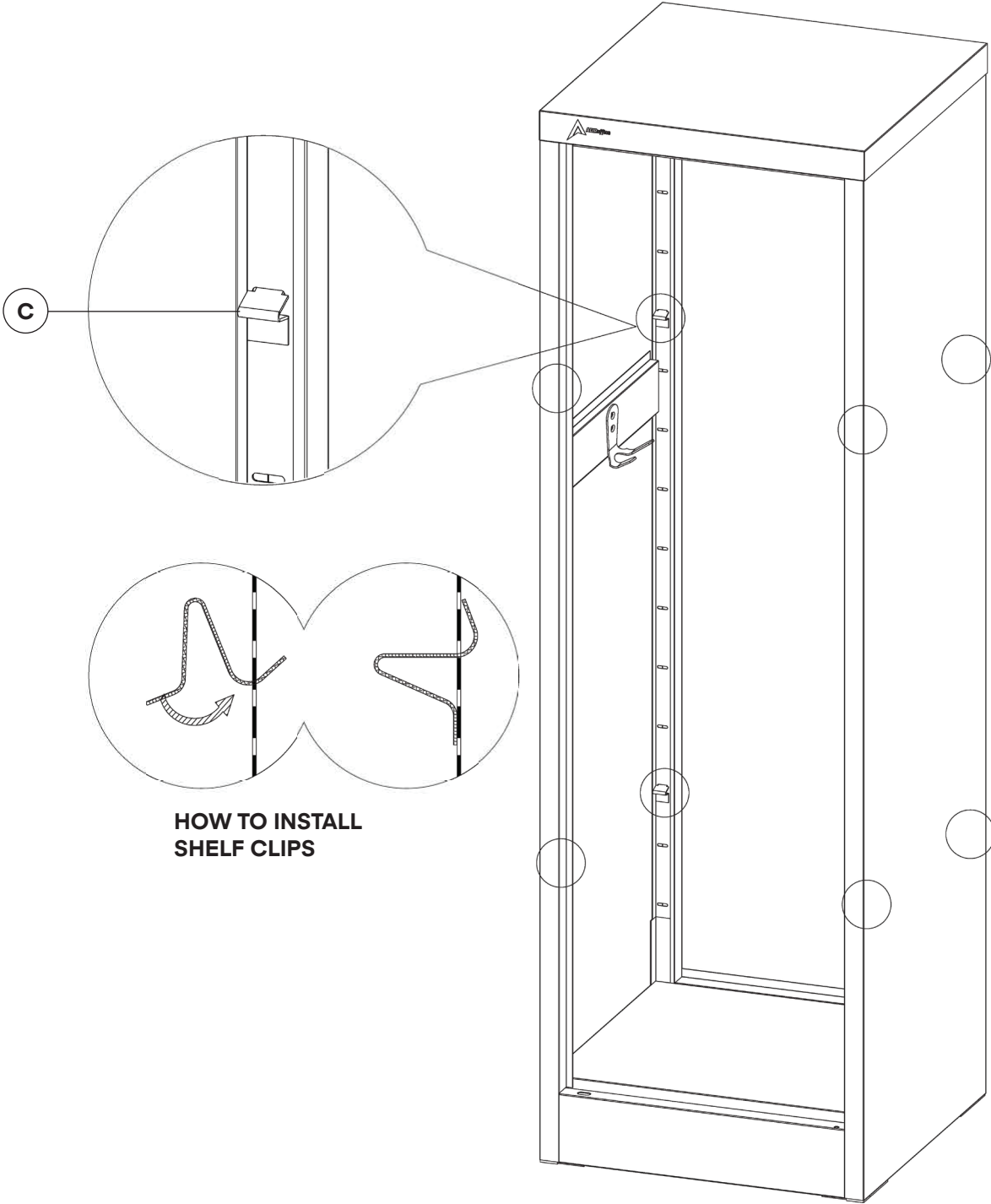

# Assembly Instructions

**STEP 10:**  
Place the Shelves (9) on the Shelf Clips (C).

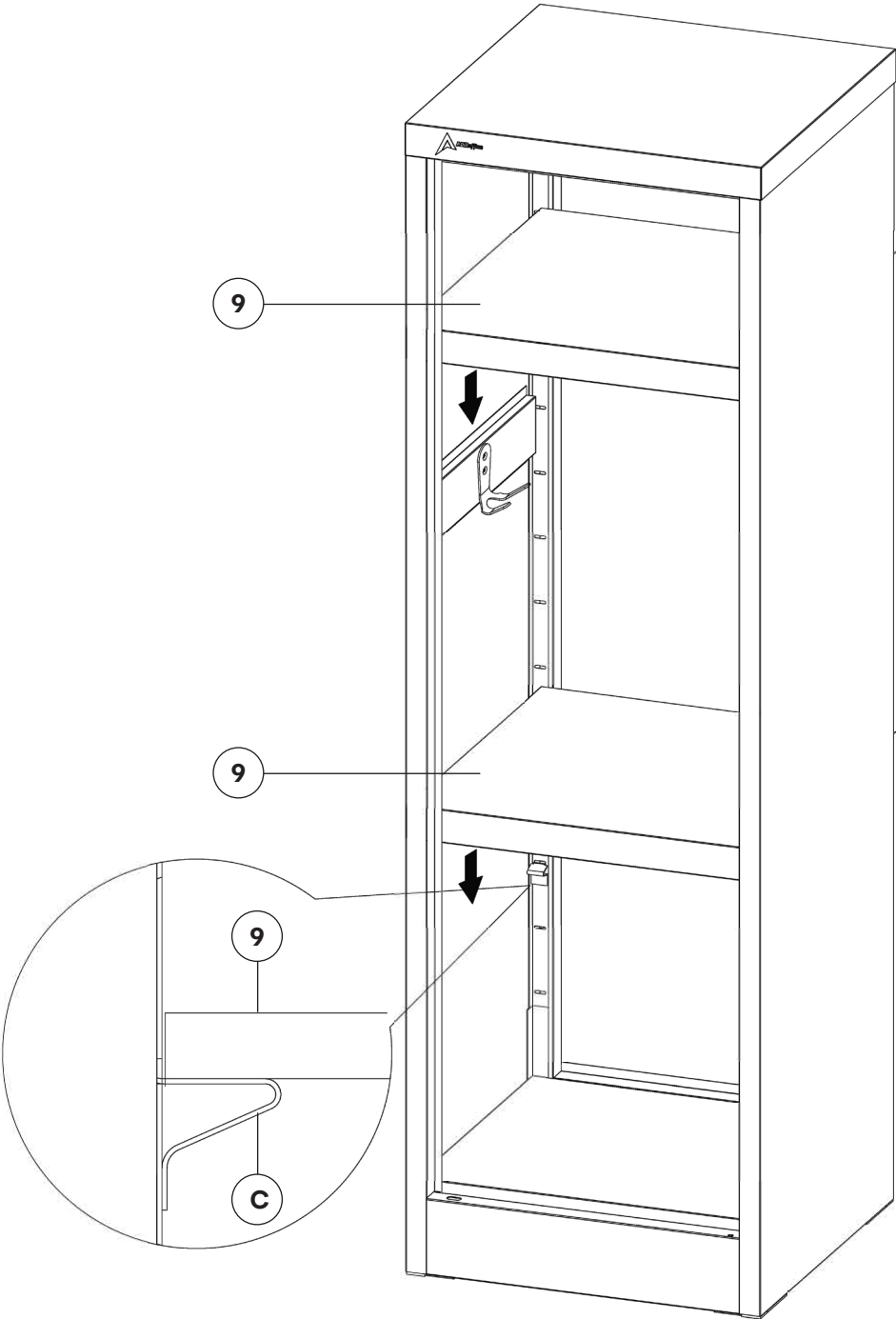

# Mounting Instructions

There are two holes near the top of the Back Panel (3) of your locker.

Place your locker where you want to install it. Using a pencil, mark the location of each of these holes on the wall.

Remove the locker(s) from the wall. In the marked locations, drill a hole large enough for the Wall Anchors (F) Make sure you don't drill it too large!

Using a Phillips screwdriver, twist each of the Wall Anchors (F) through the back of the locker and into the holes in the wall. Hand tightening is recommended; using a drill could damage the hole.

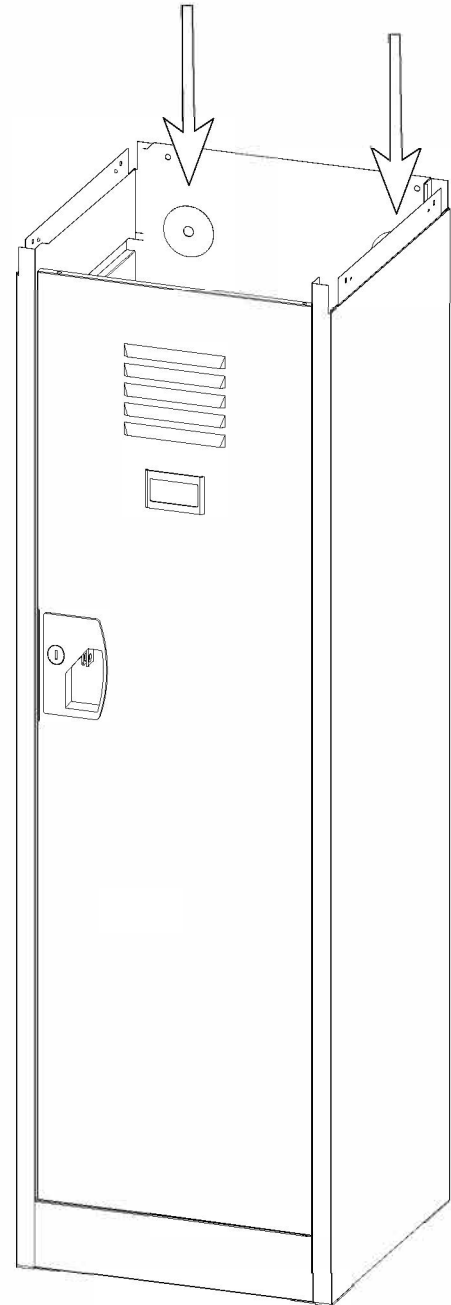
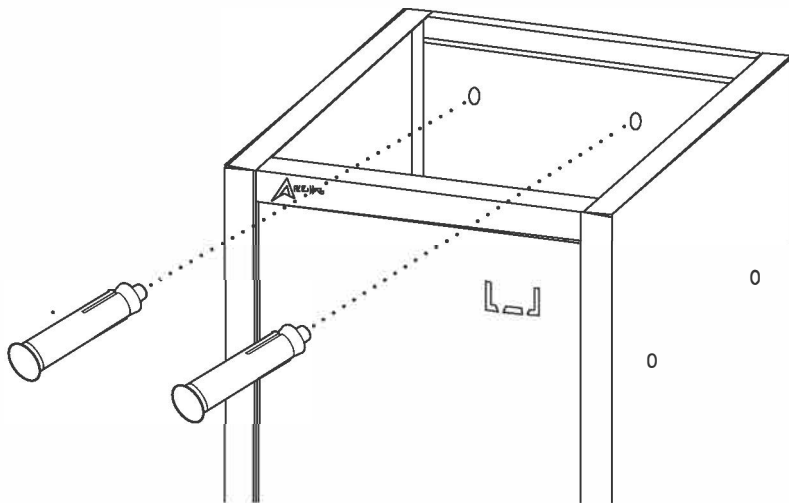

# Warranty

1. Adir Corp (the "Company" or "Tiger Companies") warrants to the purchaser that the product will be free from defects in workmanship and materials for a period of 1 year from the date of purchase. The warranty period is not extended if we repair, replace, exchange, or provide a refund for the product (as determined in our sole discretion). We may change the availability of this limited warranty at our discretion, but any changes will not be retroactive.
2. These warranties are not assignable or transferable to any other person, including, without limitation, any subsequent owner or other transferee of the product.
3. This Warranty does not apply to: (a) damage caused by misuse, tampering, abuse, neglect, or accident; (b) damage caused by improper installation, modification, or service; (c) alteration of the serial number; or (d) use that violates the instructions furnished by the Company will void this warranty.
4. The sole responsibility of the Company shall be limited to (a) the repair or replacement (in its sole discretion) of any component of the product which fails to conform to this; (b) a refund the purchase price of such product (in its sole discretion), at no cost to the purchaser for the period of the warranty, or (c) an exchange for a similar product, comparable in function and price.
5. Contact the Company directly at 1-(800)-805-1790 to obtain service under this warranty. If it becomes applicable to send a defective product to the Company, a Return Authorization Number must first be obtained from the Company. In order to obtain service under this warranty, purchaser may be required to provide the Company with the following items (a) proof of purchase, (b) photographs and or videos (of the damage, and (c) a written testimonial describing the defect.
6. Products shipped without prior Return Authorization and Return Authorization Number may not be accepted, and the Company will not be responsible for their disposition and/or cost of return to the owner.
7. The Company will not assume any responsibility for any loss or damage incurred in shipping and or delivery.
8. The product(s) must be returned within 14 calendar days of receiving the return authorization from the Company and must include the original proof of purchase for the warranty to be honored.
9. Any implied warranties that the purchaser may have are limited to the duration of the warranties described above. There are no further warranties that extend or apply beyond the face hereof, and the Company expressly disclaims and excludes any and all warranties of merchantability or fitness for a particular purpose. Some states do not allow limitations on how long an implied warranty lasts, so the above limitation may not apply to you.
10. THE REMEDIES DESCRIBED ABOVE ARE YOUR SOLE AND EXCLUSIVE REMEDIES AND THE COMPANY'S ENTIRE LIABILITY FOR ANY BREACH OF THIS LIMITED WARRANTY. OUR LIABILITY SHALL UNDER NO CIRCUMSTANCES EXCEED THE ACTUAL AMOUNT PAID BY YOU FOR THE DEFECTIVE PRODUCT, NOR SHALL WE UNDER ANY CIRCUMSTANCES BE LIABLE FOR ANY CONSEQUENTIAL, INCIDENTAL, SPECIAL OR PUNITIVE DAMAGES OR LOSSES, WHETHER DIRECT OR INDIRECT. SOME STATES DO NOT ALLOW THE EXCLUSION OR LIMITATIONS OF INCIDENTAL OR CONSEQUENTIAL DAMAGES, SO THE LIMITATION MAY NOT APPLY TO YOU.
11. This warranty gives you specific legal rights, and you may also have additional rights which vary from state to state.



**ADI629-01-SERIES**

©2023 AdirCorp

**[adircorp.com](http://adircorp.com)**